

HOSES

Product	Page	Product	Page
Working pressure, Type Approvals	345	GS Hose Components, medium press.	369
High Pressure Hoses: P1T, EN 853/G1	348	GS Hose Assembly, low pressure	370
C1TH, EN 853/G2	349	GS Hose Components, low pressure	371
CM2T / EN 857, SAE 100 R2	350	P-Serie Couplings: Ferrules	372
1PW Powerwash, 2PW Powerwash	351	Choise of Ferrule	373
SAE 100 R12, GH506/4SH	352	P-Serie Couplings: BSP Threads 60° Cone, BSP / NPT	374
SAE 100 R17, SAE 100 R19	353	JIC 74° Cone, DKOL / SKL Metric	375
M5K, M6K	354	DKOS / SKS Metric, 3000/6000 psi SAE	376
G3K, G4K	355	JIS - Komatsu - Banjo - Kobelco -	377
G5K	356	ORFS / SAE Flat Face O-ring	377
G6K	357	I-Serie Interlock Couplings: SAE 3000 / 6000 psi with O-ring	378
SAE100 R7, SAE 100 R7 - twin hose	358	Ferrules, JIC Couplings, DKOS / SKS	379
SAE100 R8, SAE100 R8 - twin hose	359	G-Serie One Piece Couplings: Choise of Couplings	380
Non-Conductive Hose, T9 Teflon hose	360	BSP Threads 60° Cone, BSP / NPT	381
Special Hoses: Powerbraid, Protectors	361	JIC 74° Cone, DKOL / SKL Metric	382
Low Pressure Hoses: GP 40, GP 60	362	DKOS / SKS Metric, 3000/6000 psi SAE	383
GP 80, ACR Megatech	363	Powerwash	384
Megavac, Adapta Flex/AF	364	GS-Serie Couplings: Ferrules, Inserts BSP 60° Cone	385
Premo Flex, 6005 Oil hose	365	UNF JIC 74° Seat, DKOS / SKS Metric	386
GS Hose Assembly, high pressure	366	SAE 3000 / 6000 psi with O-ring	387
GS Hose Components, high pressure	367	CAT Style O-ring Flange	388
GS Hose Assembly, medium pressure	368	ORFS/SAE Flat Face, Komatsu Style	389



HOSES

GS-Hydro supplies comprehensive selection of hoses and hose couplings which include BSP, NPT, JIC, Metric, SAE 3000/6000 Flanges and GS Retain Ring Flanges to various applications.

GS-Hydro hoses can meet several industry standards and type approvals of main certificate institutes. Please specify your requirements when ordering.



In order to guarantee peak performance of the hose, you should select the type of the hose according to specific conditions under which it is to be used. Therefore it is essential to obtain precise information about the application and required connections. Make sure that all requirements of the application are fulfilled.

The system pressure should not exceed published working pressures. Approved working pressures are indicated in the enclosed table.

Working Pressures / High Pressure Hoses

Hose type	Hose dimension										
	3/16"	1/4"	5/16"	3/8"	1/2"	5/8"	3/4"	1"	1 1/4"	1 1/2"	2"
P1T	120	120	120	120							
G1 /1SN		225	215	180	160	130	105	88	63	50	40
C1TH / G1H		195		160	140	105	90	70	63	50	40
G2 / 2SN		400	350	330	275	250	215	165	125	90	80
CM2T		400	350	330	275	250	215	165			
G2L		400		330	275	250	215	165	125		
1PW / 2PW			200	200	200						
4SH / GH506							420	385	350	300	250
M3K		210	210	210	210	210	210	210			
M4K		280		280	280	280	280				
M5K		350	350	350	350						
M6K		420									
G3K									210	210	210
G4K				280	280	280	280	280	280		
G5K					350	350	350	350	350	350	350
G6K				420	420	420	420	420	420	420	420
R7		190	175	155	140	105	87	70			
R8		350		280	245	195	162	142			
2A		690		690	560						
T9 / PTFE		252		172	142		96	63			

Above pressures = Approved working pressures.

Burst pressure = 4 x working pressure

HOSES

High Pressure Hose

TECHNICAL SPECIFICATION:

- Recommended:** Pilot control systems
Also suitable as washer hose
- Construction:** NBR tube
CR cover
1 wire reinforced
- Temperature:** -40°C - + 100°C.
- Approvals:** See page no 361
- Couplings:** P-Serie

Pilot Hose Pilot Control



Part No	ID Code	Hose bore		Hose mm	Min. burst pressure		Max. working pressure		Min. bend radius mm	Weight kgs. 100 m
		inch	mm		psi	bar	psi	bar		
P1T-04		1/4"	6	10,6	7000	480	1750	120	25	11
P1T-05		5/16"	8	12,3	7000	480	1750	120	30	13
P1T-06		3/8"	10	13,9	7000	480	1750	120	40	15

TECHNICAL SPECIFICATION:

- Recommended:** Hydraulic systems, lubr. oils.
- Construction:** NBR tube
1 wire reinforced
NBR/PVC cover.
- Temperature:** -40°C - + 100°C.
Intermittent + 120°C.
- Approvals:** See page no 361
- Couplings:** P-Serie and G-Serie

SAE 100 R1 S/EN 853 1SN G1 ISO 1436 1 wire non skive



Part No	ID Code	Hose bore		Hose O.D mm	Min. burst pressure		Max. working pressure		Min. bend radius mm	Weight kgs. 100 m
		inch	mm		psi	bar	psi	bar		
G1-04		1/4"	6	13,4	13050	900	3262	225	100	22
G1-05		5/16"	8	15,0	12325	850	3117	215	115	26
G1-06		3/8"	10	17,4	10440	720	2610	180	130	35
G1-08		1/2"	12	20,6	9380	640	2320	160	180	43
G1-10		5/8"	16	23,7	7540	520	1885	130	200	49
G1-12		3/4"	20	27,7	6090	420	1522	105	240	63
G1-16		1"	25	35,6	5075	350	1276	88	300	89
G1-20		1 1/4"	32	43,5	3625	250	913	63	420	119
G1-24		1 1/2"	38	50,6	2900	200	725	50	500	143
G1-32		2"	50	64,0	2320	160	580	40	630	193

SAE 100 R1 ISO 1436 High Temperature



TECHNICAL SPECIFICATION:

Recommended: Medium pressure and high-temperature hose lines.

Construction: NBR tube
1 wire braid reinforcement
CSM (Hypalon) cover.

Temperature: -40°C - +135°C.
Intermittent + 150°C.

Approvals: See page no 361

Couplings: P-Serie and G-Serie

Part No	ID Code	Hose bore		Hose O.D mm	Min. burst pressure		Max. working pressure		Min. bend radius mm	Weight kgs. 100 m
		inch	mm		psi	bar	psi	bar		
C1TH-04		1/4"	6	13,4	11165	770	2825	195	100	22
C1TH-05		5/16"	8	15,0	10150	700	2535	175	115	26
C1TH-06		3/8"	10	17,4	9135	630	2320	160	130	35
C1TH-08		1/2"	12	20,6	8120	560	2030	140	180	43
C1TH-10		5/8"	16	23,7	6090	420	1520	105	200	49
C1TH-12		3/4"	19	27,7	5075	350	1305	90	240	64
C1TH-16		1"	25	35,6	4060	280	1015	70	300	91
C1TH-20		1 1/4"	31	43,6	2500	172	625	43	420	119
C1TH-24		1 1/2"	38	50,8	2000	138	500	34	500	143

SAE 100 R2 S/EN 853 2SN G2



TECHNICAL SPECIFICATION:

Recommended: High pressure hydraulic oil lines.

Construction: NBR tube
2 wire braid reinforcement.
NBR/PVC cover

Temperature: -40°C - + 100°C.
Intermittent + 120°C.

Approvals: See page no 361

Couplings: P-Serie, G-Serie

Part No	ID Code	Hose bore		Hose O.D mm	Min. burst pressure		Max. working pressure		Min. bend radius mm	Weight kgs. 100 m
		inch	mm		psi	bar	psi	bar		
G2-04		1/4"	6	15,0	23200	1600	5800	400	100	35
G2-05		5/16"	8	16,6	20300	1400	5075	350	115	40
G2-06		3/8"	10	19,0	19140	1320	4785	330	130	52
G2-08		1/2"	12	22,2	15950	1100	3987	275	180	63
G2-10		5/8"	16	25,4	14500	1000	3625	250	200	75
G2-12		3/4"	20	29,3	12325	850	3117	215	240	91
G2-16		1"	25	38,1	9425	650	2392	165	300	134
G2-20		1 1/4"	32	48,3	7250	500	1812	125	420	192
G2-24		1 1/2"	38	54,6	5220	360	1305	90	500	223
G2-32		2"	50	67,3	4640	320	1160	80	630	278

HOSES

High Pressure Hose

TECHNICAL SPECIFICATION:

Recommended: High pressure hydraulic oil lines.

Construction: NBR tube
2 wire braid reinforcement.
CR cover

Temperature: -40°C - + 100°C.
Intermittent + 120°C.

Approvals: See page no 361

Couplings: P-Serie, G-Serie

EN 857/2SC ISO 1436

Compact hose.
Very tight bend radius



Part No	ID Code	Hose bore		Hose O.D mm	Min. burst pressure		Max. working pressure		Min. bend radius mm	Weight kg. 100 m
		inch	mm		psi	bar	psi	bar		
CM2T-04		1/4"	6	14,1	23200	1600	5800	400	51	31
CM2T-05		5/16"	8	15,5	20300	1400	5075	350	55	35
CM2T-06		3/8"	10	17,7	19140	1320	4785	330	63,5	42
CM2T-08		1/2"	12	20,8	15950	1100	3987	275	90	51
CM2T-10		5/8"	16	24,6	14500	1000	3625	250	102	70
CM2T-12		3/4"	20	27,8	12300	850	3100	215	122	81
CM2T-16		1"	25	35,8	9400	650	2400	165	153	115

Twin Hose

CM2T-06TW		3/8"	10		19140	1320	4785	330		
CM2T-08TW		1/2"	12		15950	1100	3987	275		

TECHNICAL SPECIFICATION:

Recommended: High pressure hydraulic applications at extremely low temperature.

Construction: NBR tube
2 wire braid reinforcement.
CR cover

Temperature: -57°C - + 100°C.
Intermittent + 120°C.

Couplings: P-Serie, G-Serie

SAE 100 R2 S/EN 853 2SN

Low Temperature hose



Part No	ID Code	Hose bore		Hose O.D mm	Min. burst pressure		Max. working pressure		Min. bend radius mm	Weight kg. 100 m
		inch	mm		psi	bar	psi	bar		
G2L-04		1/4"	6	14,7	23200	1600	5800	400	100	36
G2L-06		3/8"	10	18,5	19200	1320	4800	330	130	53
G2L-08		1/2"	12	21,6	16000	1100	4000	275	180	64
G2L-10		5/8"	16	24,9	14500	1000	3625	250	200	76
G2L-12		3/4"	19	29,0	12400	850	3100	215	240	91
G2L-16		1"	25	37,5	9600	650	2400	165	300	136
G2L-20		1 1/4"	31	47,5	7300	500	1825	125	420	212

1PW Powerwash 200 Bar

1 wire Non-skive
BLUE COVER



TECHNICAL SPECIFICATION:

Recommended: Use on hot and cold water high-pressure cleaning equipment where heavy-duty service is required. Suited for agricultural, sports, valet and maintenance applications. Blue PowerWash is suitable for use in hospitals, swimming pools and other applications where hygiene is often utmost important.

Construction: NBR tube
Blue NBR/PVC cover
1 wire braid reinforcement

Temperature: -40°C - + 155°C.

Couplings: P-Serie, G-Serie

Part No	ID Code	Hose bore		Hose O.D mm	Min. burst pressure		Max. working pressure		Min. bend radius mm	Weight kgs. 100 m
		inch	mm		psi	bar	psi	bar		
1PW-05B	51041401	5/16"	8	15,0	12250	850	2920	200	80	26
1PW-06B	51041402	3/8"	10	17,4	10410	720	2920	200	90	35
1PW-08B	51041403	1/2"	12	20,6	9280	640	2920	200	125	43

2PW Powerwash 400 Bar

2 wire Non-skive
BLUE COVER

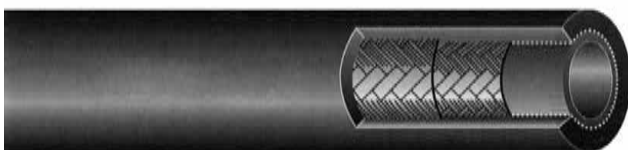

TECHNICAL SPECIFICATION:

Recommended: Use on hot and cold water high-pressure cleaning equipment where heavy-duty service is required. Suited for agricultural, sports, valet and maintenance applications. Blue PowerWash is suitable for use in hospitals, swimming pools and other applications where hygiene is often utmost importance.

Construction: NBR tube
Blue NBR/PVC cover
2 wire braid reinforcement

Temperature: -40°C - + 155°C.

Couplings: P-Serie, G-Serie

Part No	ID Code	Hose bore		Hose O.D mm	Min. burst pressure		Max. working pressure		Min. bend radius mm	Weight kgs. 100 m
		inch	mm		psi	bar	psi	bar		
2PW-05B	51041410	5/16"	8	15,6	17520	1200	5000	400	80	34
2PW-06B	51041411	3/8"	10	17,5	17520	1200	5000	400	90	41
2PW-08B	51041412	1/2"	12	20,6	15225	1050	5000	400	125	51

HOSES

High Pressure Hose

TECHNICAL SPECIFICATION:

Recommended: Very high pressure applications.
- for high pressure peaks

Construction: NBR tube, CR cover
Four alternating layers of spiralled high tensile steel wire over fabric layer.

Temperature: -40°C - + 121°C.
Intermittent + 120°C.

Approvals: See page no 361

Couplings: P-Serie, G-Serie

SAE 100 R12/EN 856 R12

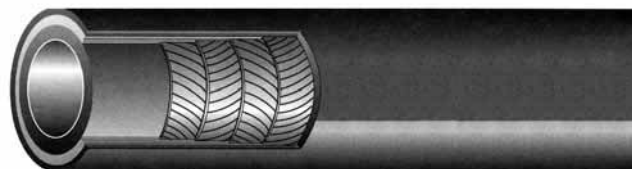

Part No	ID Code	Hose bore			Hose O.D		Min. burst pressure		Max. working pressure		Min. bend radius mm	Weight kgs. 100 m
		inch	mm	DN	inc	mm	PSI	MPa	PSI	MPa		
6EFG4K		3/8	6	10	0.81	20.5	16000	112.0	4000	28.0	65	71
8EFG4K		1/2	8	12	0.95	24.0	16000	112.0	4000	28.0	90	89
10EFG4K		5/8	10	16	1.09	27.6	16000	112.0	4000	28.0	100	113
12EFG4K		3/4	12	19	1.21	30.7	16000	112.0	4000	28.0	120	128
16EFG4K		1	16	25	1.50	38.0	16000	112.0	4000	28.0	150	188
20EFG4K		1.1/4	20	31	1.85	47.0	16000	112.0	4000	28.0	210	283

352

TECHNICAL SPECIFICATION:

Recommended: Very high pressure applications.
- for high pressure peaks

Construction: NBR tube and CR cover
Four alternating layers of spiralled high tensile steel wire over fabric layer.

Temperature: -40°C - + 100°C.
Intermittent + 120°C.

Approvals: See page no 361

Couplings: I-Serie

GH506/4SH

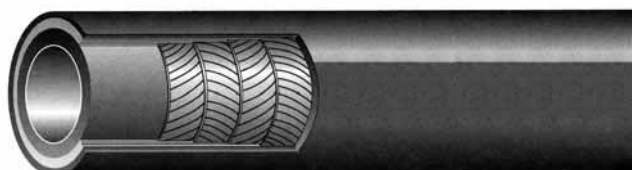

Part No	ID Code	Hose bore		Hose O.D mm	Min. burst pressure		Max. working pressure		Min. bend radius mm	Weight kgs. 100 m
		inch	mm		psi	bar	psi	bar		
506-12	51041217	3/4"	19	32,0	24400	1680	6100	420	280	153
506-16	51041218	1"	25	38,7	22300	1540	5575	385	340	206
506-20	51041219	1 1/4"	32	45,5	20440	1400	5075	350	460	242
506-24	51041220	1 1/2"	38	53,5	17520	1200	5075	300	560	328
506-32	51041221	2"	51	68,0	14600	1000	4350	250	710	450

SAE 100 R17/EN 1SC/2SC

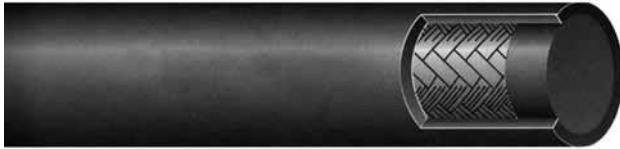

TECHNICAL SPECIFICATION:

- Recommended:** High pressure hydraulic applications
- Tube:** NBR (Nitrile).
- Reinforcement:** -4-5-6-8: one braid of steel wire
-10-12-16: two braids of steel wire
- Cover:** NBR / PVC. MSHA approval
- Temp. range:** -40°C to +100°C constant.
+120°C intermittent.
- Couplings:** P-Serie, G-Serie
- Approvals:** See page no 361

Part No	ID Code	Hose bore		Hose O.D mm	Min. burst pressure		Max. working pressure		Min. bend radius mm	Weight kgs. 100 m
		inch	mm		psi	bar	psi	bar		
M3K-04		1/4"	6	12,2	12000	840	3000	210	50	17
M3K-05		5/16"	8	15,1	12000	840	3000	210	57	26
M3K-06		3/8"	10	16,0	12000	840	3000	210	64	28
M3K-08		1/2"	12	20,2	12000	840	3000	210	89	41
M3K-10		5/8"	16	25,2	12000	840	3000	210	102	73
M3K-12		3/4"	19	29,0	12000	840	3000	210	121	91
M3K-16		1"	25,4	37,6	12000	840	3000	210	152	155

EN 857/2SC SAE 100 R 19



TECHNICAL SPECIFICATION:

- Recommended:** High pressure hydraulic applications
- Tube:** NBR (Nitrile).
- Reinforcement:** Two braids of high tensile steel wire
- Cover:** NBR / PVC. MSHA approval
- Temp. range:** -40°C to +100°C constant.
+120°C intermittent.
- Couplings:** P-Serie, G-Serie
- Approvals:** See page no 361

Part No	ID Code	Hose bore		Hose O.D mm	Min. burst pressure		Max. working pressure		Min. bend radius mm	Weight kgs. 100 m
		inch	mm		psi	bar	psi	bar		
M4K-04		1/4"	6	13,7	16000	1120	4000	280	50	33
M4K-05		5/16"	8	15,4	16000	1120	4000	280	57	34
M4K-06		3/8"	10	17,5	16000	1120	4000	280	64	46
M4K-08		1/2"	12	20,8	16000	1120	4000	280	89	51
M4K-10		5/8"	16	24,9	16000	1120	4000	280	102	74
M4K-12		3/4"	19	29,0	16000	1120	4000	280	121	93

HOSES

High Pressure Hose

EN 857 SC

TECHNICAL SPECIFICATION:

- Recommended:** High pressure hydraulic applications
- Tube:** NBR (Nitrile).
- Reinforcement:** Two braids of high tensile steel wire.
- Cover:** NBR / PVC. MSHA approval
- Temp. range:** -40°C to +100°C constant.
+120°C intermittent.
- Couplings:** P-Serie, G-Serie
- Approvals:** See page no 361



Part No	ID Code	Hose bore		Hose O.D mm	Min. burst pressure		Max. working pressure		Min. bend radius mm	Weight kgs. 100 m
		inch	mm		psi	bar	psi	bar		
M5K-04		1/4"	6	13,7	20000	1400	5000	350	50	30
M5K-05		5/16"	8	15,4	20000	1400	5000	350	57	34
M5K-06		3/8"	10	17,5	20000	1400	5000	350	64	41
M5K-08		1/2"	12	20,8	20000	1400	5000	350	90	51

354

EN 857/2SC

TECHNICAL SPECIFICATION:

- Recommended:** High pressure hydraulic applications
- Tube:** NBR (Nitrile).
- Reinforcement:** Two braids of high tensile steel wire.
- Cover:** NBR / PVC. MSHA approval
- Temp. range:** -40°C to +100°C constant.
+120°C intermittent.
- Couplings:** P-Serie, G-Serie
- Approvals:** See page no 361



Part No	ID Code	Hose bore		Hose O.D mm	Min. burst pressure		Max. working pressure		Min. bend radius mm	Weight kgs. 100 m
		inch	mm		psi	bar	psi	bar		
M6K-04	51041299	1/4"	6	15,0	24000	1680	6000	420	50	35

SAE 100 R12/4SP

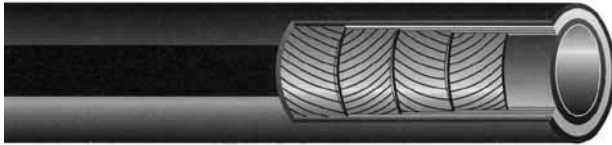

TECHNICAL SPECIFICATION:

- Recommended:** Extreme high pressure and high impulse hydr. applications
- Tube:** CR (Cloroprebe)
- Reinforcement:** Four alternating layers of spiralled, high tensile steel wire.
- Cover:** CR (Cloroprene).
MSHA Approval
- Temp. range:** -40°C to +121°C
- Couplings:** P-Serie, GS-Serie
- Approvals:** See page no 361

Part No	ID Code	Hose bore		Hose O.D mm	Min. burst pressure		Max. working pressure		Min. bend radius mm	Weight kgs. 100 m
		inch	mm		psi	bar	psi	bar		
G3K-20		1 1/4"	31	47,0	12000	840	3000	210	419	290
G3K-24		1 1/2"	38	53,6	12000	840	3000	210	508	320
G3K-32		2"	51	66,8	12000	840	3000	210	635	439

SAE 100 R12/4SP

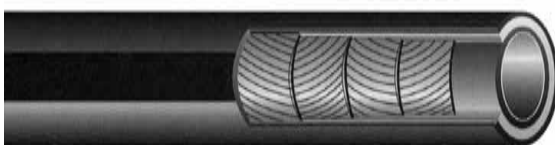

- Recommended for:** Extremely high pressure and high impulse hydraulic applications.
- Tube:** NBR (Nitrile).
- Reinforcement:** Four alternating layers of spiralled, high tensile steel wire.
- Cover:** CR (Chloroprene). MSHA Approval.
- Temperature range:** -40°C to +121°C.
For water emulsions, etc. see page
- Couplings:** GS-Serie, P-Serie
- Approvals:** See page no 361
- Characteristics and benefits:** Extremely flexible.
Superior flex impulse performance: tested to 1000000 impulse cycles at 50% of EN 856 R12 and SAE 100R12 bend radii.
50% of EN 856 4SP bend radius.

Part No	ID Code	Hose bore		Hose O.D mm	Min. burst pressure		Max. working pressure		Min. bend radius mm	Weight kgs. 100 m
		inch	mm		psi	bar	psi	bar		
G4K-10		5/8"	16	28,2	16000	1120	4000	280	102	120
G4K-12		3/4"	19	30,7	16000	1120	4000	280	122	131
G4K-16		1"	25	38,1	16000	1120	4000	280	152	193
G4K-20		1 1/4"	31	47,0	16000	1120	4000	280	419	289

HOSES

High Pressure Hose

- Recommended for:** Extremely high pressure and high impulse hydraulic applications.
- Tube:** NBR: 08-20 CR.24-32 (Cloroprene).
- Reinforcement:** **-08-10-12-16**
Four alternating layers of spiralled, high tensile steel wire.
-20-24-32 : six layers.
- Cover:** CR (Chloroprene). MSHA Approval.
- Temperature range:** -40°C to +121°C.
- Couplings:** GS-Serie, I-Serie
- Approvals:** See page no 361
- Characteristics and benefits:** Extremely flexible.
Superior flex impulse performance: tested to 1000000 impulse cycles at 80% of EN 856 4SP/4SH bend radius at rated working pressure.

SAE 100 R13/4SH/4SP

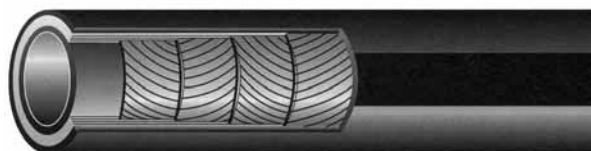

356

Part No	ID Code	Hose bore		Hose O.D mm	Min. burst pressure		Max. working pressure		Min. bend radius mm	Weight kgs. 100 m
		inch	mm		psi	bar	psi	bar		
G5K-08		1/2"	12	23,9	20000	1400	5000	350	178	89
G5K-10		5/8"	16	28,2	20000	1400	5000	350	203	116
G5K-12		3/4"	19	32,0	20000	1400	5000	350	241	147
G5K-16		1"	25	38,9	20000	1400	5000	350	305	228
G5K-20		1 1/4"	31	50,0	20000	1400	5000	350	419	408
G5K-24	51041306	1 1/2"	38	57,4	20000	1400	5000	350	508	482
G5K-32	51041307	2"	51	71,1	20000	1400	5000	350	635	719

SAE 100 R15/4SH/4SP



- Recommended for:** Extremely high pressure and high impulse applications such as hydrostatic transmissions, etc.
- Tube:** NBR: 08-20 CR: 24-32 (Cloroprene) MSHA Approval.
- Reinforcement:** Four (six for -20) alternating layers of spiralled, high tensile steel wire.
- Cover:** CR (Chloroprene). MSHA approval.
- Temperature range:** -40°C to +121°C. For water emulsions, etc. see page
- Standards:**
- Couplings:** GS-Serie, I-Serie
- Approvals:** See page no 361
- Characteristics and benefits:** Extremely flexible. Superior flex impulse performance: tested to 1000000 impulse cycles at reduced bend radii. 80% of EN 856 4SP/4SH bend radius at rated working pressure.

NOTE:

G4K-, G5K- and G6K-hoses can be supplied with a special CR tube and cover to withstand 300x the abrasion of a standard hose. This hose is suitable in reverse bending applications or for constant bending at minimum bend radius.

G4K-, G5K- and G6K-hoses can be supplied for applications where biodegradable hydraulic fluids like syntethic esters, polyglycols and vegetable oils are used.

Ask GS-Hydro for more details.

Part No	ID Code	Hose bore		Hose O.D mm	Min. burst pressure		Max. working pressure		Min. bend radius mm	Weight kgs. 100 m
		inch	mm		psi	bar	psi	bar		
G6K-06	51041300	3/8"	10	20,3	24000	1680	6000	420	127	73
G6K-08	51041301	1/2"	12	23,9	24000	1680	6000	420	178	89
G6K-10	51041302	5/8"	16	28,2	24000	1680	6000	420	203	116
G6K-12	51041303	3/4"	19	32,0	24000	1680	6000	420	241	147
G6K-16	51041304	1"	25	38,9	24000	1680	6000	420	305	228
G6K-20	51041305	1 1/4"	31	50,0	24000	1680	6000	420	419	408
G6K-24	51041308	1 1/2"	38	57,4	24000	6000	6000	420	508	482
G6K-32		2"	51	71,1	24000	6000	6000	420	635	730

HOSES

High Pressure Hose

TECHNICAL SPECIFICATION:

Recommended: Air, water and hydraulic oil lines.

Very flexible.

Construction: Polymer tube, polyester reinforcement.

Polymer cover.

Temperature: -40°C - + 100°C.

Approvals:

Couplings: P-serie, G-Serie

1P - SAE100 R7

Thermoplast



Part No	ID Code	Hose bore		Hose O.D mm	Min. burst pressure		Max. working pressure		Min. bend radius mm	Weight kgs. 100 m
		inch	mm		psi	bar	psi	bar		
R7-04		1/4"	6,4	12,2	11000	770	2750	190	50	9,5
R7-05		5/16"	8,0	14,3	10000	700	2500	175	60	11,0
R7-06		3/8"	9,6	16,0	9000	630	2250	155	80	13,5
R7-08		1/2"	12,7	20,3	8000	560	2000	140	95	19,0
R7-10		5/8"	15,9	23,5	6000	420	1500	105	130	-
R7-12		3/4"	19,0	26,5	5000	350	1250	87	185	26,0
R7-16		1"	25,0	32,5	4000	280	1000	70	230	30,0

358

1PTW - SAE100 R7

Twin hose

Thermoplast

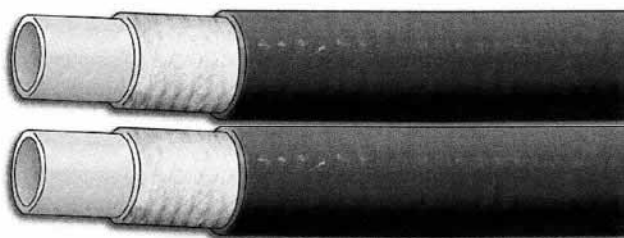

TECHNICAL SPECIFICATION:

Recommended: Air, water and hydraulic oil lines.

Very flexible.

Construction: Polymer tube, polyester reinforcement.

Polymer cover.

Temperature: -40°C - + 100°C.

Approvals:

Couplings: P-serie, G-Serie

Part No	ID Code	Hose bore		Hose O.D mm	Min. burst pressure		Max. working pressure		Min. bend radius mm	Weight kgs. 100 m
		inch	mm		psi	bar	psi	bar		
R7-04TW		1/4"	6,50	24,0	11000	758	2750	190	50	18,5
R7-06TW		3/8"	9,50	32,5	9000	620	2250	155	80	26,0
R7-08TW		1/2"	13	41,0	8000	552	2000	138	95	30,0

1A - SAE100 R8 Thermoplast

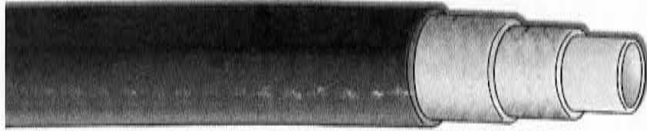

TECHNICAL SPECIFICATION:

- Recommended:** Air, water and hydraulic oil lines.
Very flexible.
- Construction:** Polymer tube, Kevlar reinforcement.
Polymer cover.
- Temperature:** -40°C - + 100°C.
- Approvals:**
- Couplings:** P-Serie, G-Serie

Part No	ID Code	Hose bore		Hose O.D mm	Min. burst pressure		Max. working pressure		Min. bend radius mm	Weight kgs. 100 m
		inch	mm		psi	bar	psi	bar		
R8-04		1/4"	6,5	12,3	20300	1400	5075	350	50	9,5
R8-06		3/8"	9,5	16,7	16240	1120	4060	280	80	13,5
R8-08		1/2"	13	20,5	14210	980	3550	245	95	19,0
R8-10		5/8"	16	24,5	11300	780	2830	195	130	-
R8-12		3/4"	19	28,0	9430	650	2350	162	185	26,0
R8-16		1"	25	34,7	8270	570	2060	142	230	30,0

1ATW - SAE100 R8 Twin hose Thermoplast

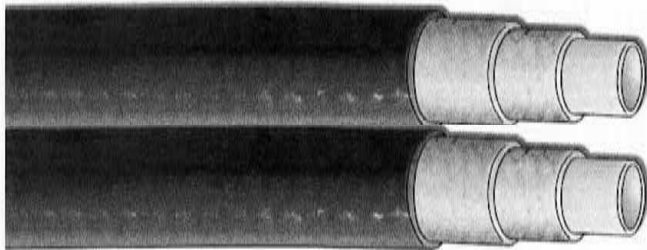

TECHNICAL SPECIFICATION:

- Recommended:** Air, water and hydraulic oil lines.
Very flexible.
- Construction:** Polymer tube, Kevlar reinforcement.
Polymer cover.
- Temperature:** -40°C - + 100°C.
- Approvals:**
- Couplings:** P-Serie, G-Serie

Part No	ID Code	Hose bore		Hose O.D mm	Min. burst pressure		Max. working pressure		Min. bend radius mm	Weight kgs. 100 m
		inch	mm		psi	bar	psi	bar		
R8-04TW		1/4"	6,50	25,0	20300	1400	5075	350	50	18,5
R8-06TW		3/8"	9,50	34,0	16240	1120	4060	280	80	23,0
R8-08TW		1/2"	13	41,0	14210	980	3550	245	95	30,0

HOSES

High Pressure Hose

TECHNICAL SPECIFICATION:

- Recommended:** Hydraulic and lubricating oil lines
- non conductive.
- Construction:** Hytrel / Polymer tube, with Kevlar reinforcement, fire resistant
Polymer cover with Kevlar reinforcement.
- Cover:** **Orange** polyurethan.
- Temperature:** -40°C - + 100°C.
- Approvals:**
- Couplings:** 1-4 wire swaged couplings
- Ferrule:** 394

Non-Conductive Hose



Part No	ID Code	Hose bore		Hose O.D mm	Min. burst pressure		Max. working pressure		Min. bend radius mm	Weight kgs. 100 m
		inch	mm		psi	bar	psi	bar		
375-04		1/4"	6,4	12,9	20000	1380	5000	345	50	9,5
375-06		3/8"	9,5	16,8	16000	1140	4000	280	80	13,5
375-08		1/2"	12,7	20,5	14000	966	3500	245	95	23,0
375-10		5/8"	16,0	24,5	11300	780	2830	195	130	-
375-12		3/4"	19,1	27,5	9000	631	2250	160	185	26,0
375-16		1"	25,1	34,7	8270	570	2060	140	230	36,0

360

TECHNICAL SPECIFICATION:

- Recommended** Aggressive fluids and high temperature applications.
- Construction:** PTFE tube, stainless steel braid
- Temperature:** -60°C - + 260°C.
- Approvals:**
- Couplings:** P-Serie, G-Serie

T9 Teflon hose

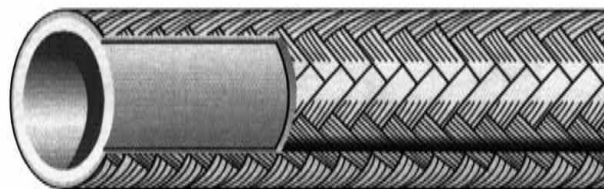

Part No	ID Code	Hose bore		Hose O.D mm	Min. burst pressure		Max. working pressure		Min. bend radius mm	Weight kgs. 100 m
		inch	mm		psi	bar	psi	bar		
T9-04		1/4"	6,4	9	11000	758	3700	252	76	9,7
T9-06		3/8"	9,5	12	9000	517	2500	172	114	14,0
T9-08		1/2"	12,7	16	8000	427	2250	142	127	21,0
T9-12		3/4"	19,1	24	4200	290	1386	96	146	37,0
T9-16		1"	25,4	30	3000	207	990	63	266	57,0

Powerbraid



TECHNICAL SPECIFICATION:

- Recommended: Hydraulic oil lines, and seismic applications.
- Construction: Neoprene tube.
Reinforced with 4 layers of high tensile steel wires.
Neoprene cover.
- Temperature: -40°C - + 93°C
- Couplings: Powerbraid couplings.
- Lengths: 60' maximum.

Part No	ID Code	Hose bore		Hose O.D mm	Test pressure		Max. working pressure		Min. bend radius mm	Weight kgs. 100 m
		inch	mm		psi	bar	psi	bar		
3670-40		2 1/2"	64	93,5	3000	207	1500	103	610	526
3670-48		3"	76	105,5	3000	207	1500	103	762	863

HEAT Protector Sleeve

Part No	Dim. Inch	Dim. mm.
Silco - 08	1/2"	13 mm
Silco - 10	5/8"	16 mm
Silco - 12	3/4"	19 mm
Silco - 16	1"	25 mm
Silco - 20	1 1/4"	32 mm
Silco - 22	1 3/8"	34 mm
Silco - 26	1 5/8"	41,5 mm
Silco - 36	2 1/4"	57 mm
Silco - 40	2 1/2"	63,5 mm
Silco - 48	3"	76 mm
Silco - 56	3 1/2"	89 mm
Silco - 64	4"	102 mm
Silco - 72	4 1/2"	115 mm
Silco - 80	5"	127 mm

HEAT PROTECTOR FOR HOSES, CABLES, Etc.

- Material: Braided fiberglass
- Outside: Heat resistant silicone rubber
- Temperature: Max 800°C - 30 minutes.
Protects continuously to 500° F

Hose Protector

Part No	Length	Dimension	
		Min.	Max.
187 953	6 meter	40	55
187 954	6 meter	55	70
187 955	6 meter	70	90
187 956	6 meter	80	100
187 958	6 meter	95	130
187 959	6 meter	120	150
187 960	6 meter	140	190

Other dimensions on request.

Hose Protector PVC - spiral

Part No	I.D. mm
1708.95	17
1710.95	22
1714.95	29
1722.95	38

Tape for Assembling

TAPE Dimension
1"
2"
3"

Hose Protector Steel

Part No	Hose dia.
1447.95	1/2"
1450.95	3/4"
1454.95	1"
1456.95	1 1/4"
1459.95	1 1/2"
1463.95	2"

HOSES

Low Pressure Hose

TECHNICAL SPECIFICATION:

Recommended: General air service up to + 80°C and general water service up to + 100°C applications requiring maximum flexibility and high abrasion resistance.

Resistance to ozone and weather influences.

Construction: EPDM Tube (Type P - black).
One or two textile reinforced.
EPDM Cover (Type P - black)

Temperature: -40°C - + 100°C.
Intermittent + 120°C.

Couplings: G-Serie

GP 40 MULTIPURPOSE HOSE (Air and Water)



Part No	ID Code	Hose bore		Hose O.D mm	Min. burst pressure		Max. working pressure		Min. bend radius mm	mm/hg	Weight kgs. 100 m
		inch	mm		psi	bar	psi	bar			
GP40-04		1/4"	6	12	560	40	190	13	45	760	11
GP40-05		5/16"	8	15	580	40	190	13	65	760	16
GP40-06		3/8"	10	17	580	40	190	13	75	760	19
GP40-08		1/2"	13	20,5	580	40	190	13	90	635	25
GP40-10		5/8"	16	24	580	40	190	13	115	500	31
GP40-12		3/4"	19	28	580	40	190	13	135	500	41
GP40-16		1"	25	35	580	40	190	13	180	250	58
GP40-20		1 1/4"	32	44	580	40	190	13	200	250	89
GP40-24		1 1/2"	38	51	580	40	190	13	300	250	112

TECHNICAL SPECIFICATION:

Recommended: Hot water wash down applications up to + 100°C, and general industrial applications such as oil and hydraulic fluids (+100°C), alcohols and aqueous solutions.

Construction: NBR
One fibre braid reinforcement.
NBR Cover

Temperature: -40°C - + 100°C.

Couplings: G-Serie

GP 60 MULTIPURPOSE HOSE (Hot water - hydr. applications)



Part No	ID Code	Hose bore		Hose O.D mm	Min. burst pressure		Max. working pressure		Min. bend radius mm	mm/hg	Weight kgs. 100 m
		inch	mm		psi	bar	psi	bar			
GP60-04		1/4"	6,5	12,7	870	60	290	20	45	760	13
GP60-05		5/16"	8,2	15	870	60	290	20	65	760	16
GP60-06		3/8"	9,9	17	870	60	290	20	75	760	19
GP60-08		1/2"	13,2	20,5	870	60	290	20	100	635	25
GP60-10		5/8"	16,0	24	870	60	290	20	115	500	33
GP60-12		3/4"	19,0	29	870	60	290	20	135	500	49
GP60-16		1"	25,8	35	870	60	290	20	160	500	56

GP 80 MULTIPURPOSE HOSE



TECHNICAL SPECIFICATION:

Recommended: General industrial applications such as oil, alcohols, aqueous solutions, hydraulic fluids, acids, detergents and chemicals.

Static conductive for more security.

Construction: NBR Tube
One or two fibre reinforced.
NBR Cover

Temperature: -40°C - +100°C.

Couplings: G-Serie

Part No	ID Code	Hose bore		Hose O.D mm	Min. burst pressure		Max. working pressure		Min. bend radius mm	mm/hg	Weight kgs. 100 m
		inch	mm		psi	bar	psi	bar			
GP80-04		1/4"	6,5	12,7	1600	110	540	37	35	760	13
GP80-05		5/16"	8,2	15,0	1600	110	540	37	50	760	16
GP80-06		3/8"	9,9	17,0	1600	110	540	37	60	760	19
GP80-08		1/2"	13,2	20,5	1600	110	540	37	70	635	25
GP80-10		5/8"	16,0	24,2	1300	90	440	30	90	500	33
GP80-12		3/4"	19,0	29,0	1300	90	440	30	110	500	49
GP80-16		1"	25,8	35,0	1300	90	440	30	130	500	56
GP80-20		1 1/4"	32,0	42,8	1300	90	440	30	200	250	81
GP80-24		1 1/2"	38,0	51,0	1300	90	440	30	300	250	140
GP80-32		2"	51,0	64,0	1300	90	440	30	500	150	170

ACR Megatech MEDIUM PRESSURE

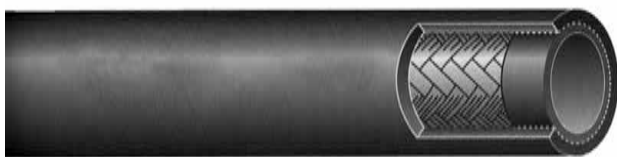

TECHNICAL SPECIFICATION:

Recommended: Pressurised hot oil return lines and air compressor lines, power steering, tilt cab cylinders engine and transmission coolant and filtration lines.

Construction: CPE Tube (Chlorinated Polyethylene). One braid of high tensile steel wire. Tube - Oil resistant textile braid with synthetic rubber. MSHA approval.

Temperature: -40°C - +150°C. for oil,
-40°C - +120°C. for air and water.
-40°C - +100°C. for phosphate ester

Couplings: G-Serie, GL-Serie

Benefits: Very good resistance to weathering and ozone

Part No	ID Code	Hose bore		Hose O.D mm	Min. burst pressure		Max. working pressure		Min. bend radius mm	mm/hg	Weight kgs. 100 m
		inch	mm		psi	bar	psi	bar			
ACR-16		1"	25	33	4000	280	1000	70	150	760	71
ACR-24		1 1/2"	38	49,5	2000	140	500	35	380	760	149
ACR-32		2"	51	63,0	2000	140	500	35	460	760	205
ACR-40		2 1/2"	63	75,4	2000	140	500	35	560	760	219
ACR-48		3"	76	86,9	2000	140	500	35	610	760	274

HOSES

Low Pressure Hose

TECHNICAL SPECIFICATION:

Recommended: Petroleum and waterbas hydraulic fluids in suction lines or in low pressure return lines.

Construction: NBR Tube

Reinforcement: -12-16-20 fibre braid with helical spiral wire
-24-64 spiralled fibre with helical spiral wire.
CR (Chloroprene) Cover

Temperature: -40°C - + 135°C constant.
-40°C - + 150°C intermittent.

Standards: SAE 100R4

Couplings: G-Serie, GL-Serie

Benefits: Half the bend radius of SAE 100 R4
Flexible and lightweight

MEGAVAC SAE 100R4

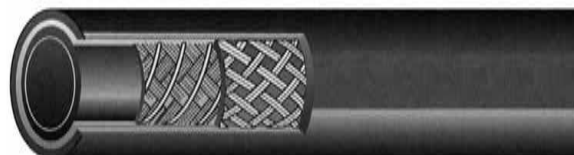

Part No	ID Code	Hose bore		Hose O.D mm	Min. burst pressure		Max. working pressure		Min. bend radius mm	mm/hg	Weight kgs. 100 m
		inch	mm		psi	bar	psi	bar			
MEGA-12		3/4"	19,0	31	1400	97	350	24	64	635	62
MEGA-16		1"	25,8	36,8	1400	97	350	24	72	635	75
MEGA-20		1 1/4"	31	44,7	1000	69	250	17	102	635	92
MEGA-24		1 1/2"	35	51,1	650	45	162	11	127	635	106
MEGA-32		2"	51	63,8	450	31	112	8	152	635	170
MEGA-36		2 1/4"	57	70,1	350	24	86	6	178	635	188
MEGA-40		2 1/2"	68	76,7	275	19	65	5	178	635	204
MEGA-48		3"	76	89,2	250	17	62	4	229	635	241
MEGA-56		3 1/2"	89	101,9	225	15	56	4	254	635	263
MEGA-64		4"	102	114,6	225	15	56	4	305	635	300

TECHNICAL SPECIFICATION:

Recommended: Air and water applications requiring maximum flexibility. Good resistance to animal fat and vegetable oils.

Construction: EPDM Tube
Syntetic high tensile cords.
EPDM Black. All sizes through 1/2" are perforated.

Temperature: -40°C - + 100°C.
Intermittent 110°C

Couplings: G-Serie

Adapta Flex / AF MULTIPURPOSE HOSE



Part No	ID Code	Hose bore		Hose O.D mm	Min. burst pressure		Max. working pressure		Min. bend radius mm	mm/hg	Weight kgs. 100 m
		inch	mm		psi	bar	psi	bar			
AF-04		1/4"	6	11,9	600	42	200	14	76	762	13
AF-06		3/8"	10	16,8	600	42	200	14	76	762	20
AF-08		1/2"	13	20,5	600	42	200	14	127	635	30
AF-10		5/8"	16	23,6	300	42	200	14	152	508	33
AF-12		3/4"	19	27,4	300	42	200	14	152	381	43
AF-16		1"	25	35,3	300	42	200	14	203	254	66
AF-20		1 1/4"	32	43,9	750	51	250	17	254	254	102
AF-24		1 1/2"	38	50,3	750	51	250	17	305	254	116

Premo Flex / PF MULTIPURPOSE HOSE



TECHNICAL SPECIFICATION:

- Recommended:** Applications requiring a premium grade spiral hose with excellent flexibility and maximum resistance to air, water, petroleum oils, gasoline, kerosene and fuel oils (to + 48°C) and lubrication oils (to + 100°C)
- Construction:** NBR Tube. Syntetic high tensile cords. Modified red nitrile Cover
- Temperature:** -40°C - + 100°C.
- Couplings:** G-Serie
- Benefits:** Non conductive at 1000volts DC. Meets electrical resistance of one megaohm per inch when subjected to 1000 volts DC. Storage and use may adversely affect electrical properties.

Part No	ID Code	Hose bore		Hose O.D mm	Min. burst pressure		Max. working pressure		Min. bend radius mm	mm/hg	Weight kgs. 100 m
		inch	mm		psi	bar	psi	bar			
PF-04		1/4"	6	12,7	750	60	250	17	50	762	13
PF-06		3/8"	10	16,8	750	60	250	17	76	762	20
PF-08		1/2"	13	21,6	750	60	250	17	102	635	33
PF-10		5/8"	16	24,9	750	60	250	17	127	506	39
PF-12		3/4"	19	29,2	750	60	250	17	127	506	52
PF-16		1"	25	37,3	750	60	250	17	203	254	62
PF-20		1 1/4"	32	44,5	750	60	250	17	254	254	98
PF-24		1 1/2"	38	50,8	750	60	250	17	305	254	115

6005 Oil hose

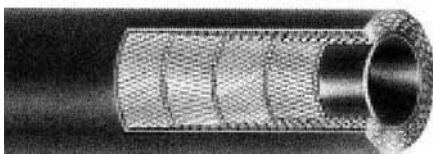

TECHNICAL SPECIFICATION:

- Recommended:** Transport of hydraulic and fuel oils.
- Construction:** Nitrile tube
textile reinforcement
Neoprene cover.
- Temperature:** -40°C - +100°C
- Lengths:** 40 m.
Other lengths on request.

Part No 6005-	ID Code	I.D.	O.D.	W.P	Burst pressure	Bend radius	Weight kg/m
24		1 1/2"	51	10	30	280	1,3
32		2"	65	10	30	280	1,3
40		2 1/2"	77	10	30	440	2,3
48		3"	92	10	30	526	2,9
56		3 1/2"	106	10	30	630	3,5
64		4"	118	10	30	702	4,3
80		5"	145	10	30	876	5,8
96		6"	170	10	30	1050	6,9
128		8"	224	10	30	1420	9,2

365

GS-FLANGE SYSTEM

TUBES & PIPES

CLAMPS

VALVES

BITE TYPE FITTINGS

SAE J514 JIC FLARE FITTINGS

HOSES & HOSE COUPLINGS

ADAPTORS

SPECIAL SOLUTIONS

MACHINES

TECHNICAL INFORMATION

HOSES

GS Hose Assembly, High Pressure

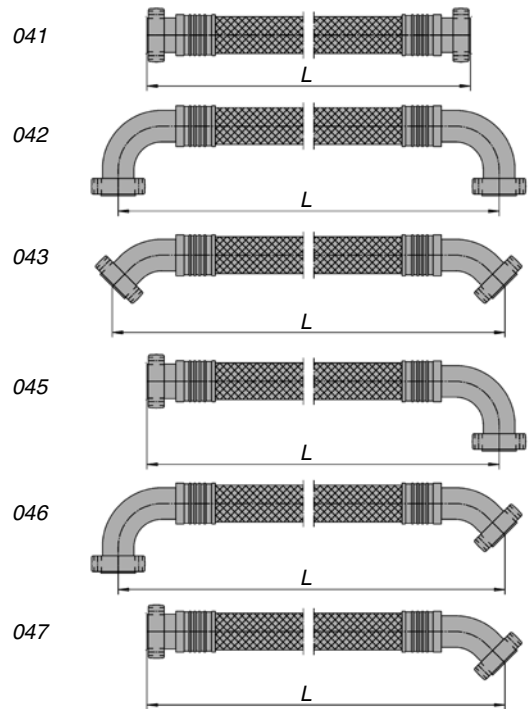
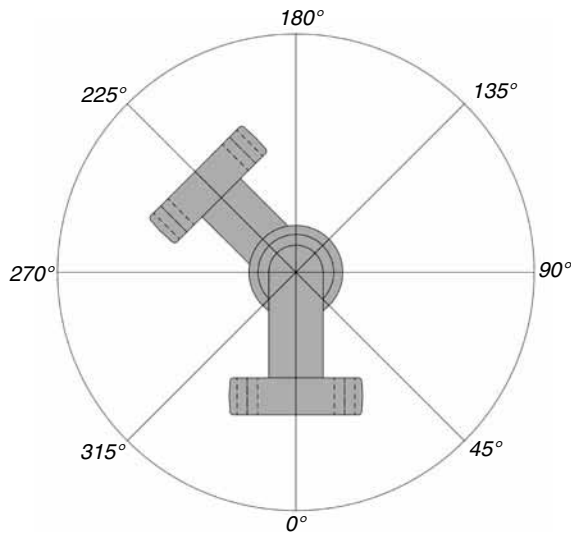

Hose assembly for GH 506 -hose and GS-SAE high pressure flanges.

SAE 3000 psi Flanges

Size	Part No	Working Pressure for hose assembly (bar)	Burst Pressure for hoses (bar)	Bending Radius
3/4"	312041–312047	210	1600	300
1"	316041–316047	210	1440	340
1 1/4"	320041–320047	210	1300	460
1 1/2"	324041–324047	210	1200	560
2"	332041–332047	210	1000	710

SAE 6000 psi Flanges

Size	Part No	Working Pressure for hose assembly (bar)	Burst Pressure for hoses (bar)	Bending Radius
3/4"	612041–612047	400	1600	300
1"	616041–616047	360	1440	340
1 1/4"	620041–620047	350	1300	460
1 1/2"	624041–624047	300	1200	560
2"	632041–632047	250	1000	710

Part number does not include bolts
When higher working pressure are requested, contact to GS-Hydro for more detailed information.

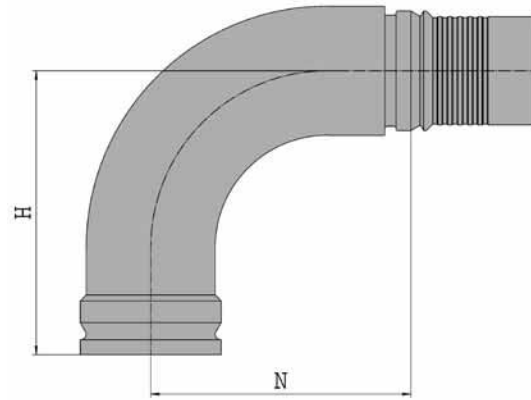
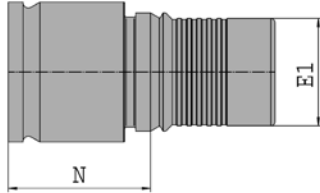

Hose Insert – straight

Size	Part No	ID Code	N	E1
3/4"	12020	51050010	46	15
1"	16020	51050014	50	20
1 1/4"	20020	51050018	52	26.5
1 1/2"	24020	51050022	54	32.4
2"	32020	51050026	59	44.5

Component material: St 52
Other materials by request

Hose Insert – 90°

Size	Part No	ID Code	N	H
3/4"	12021	51050420	59	69
1"	16021	51050424	71	78
1 1/4"	20021	51050428	80	88
1 1/2"	24021	51050436	92	102
2"	32021	51050440	115	126

Component material: St 52
Other materials by request

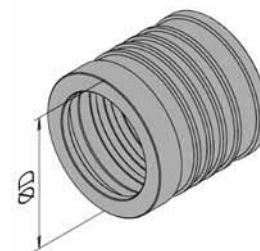
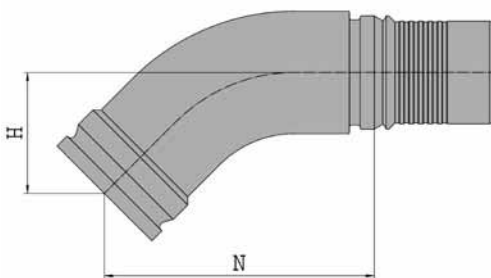

Hose Insert – 45°

Size	Part No	ID Code	N	H
3/4"	12022	51050400	78	36
1"	16022	51050404	89	40
1 1/4"	20022	51050408	96	43
1 1/2"	24022	51050412	109	50
2"	32022	51050416	131	60

Component material: St 52
Other materials by request

Hose Ferrule

Size	Part No	ID Code	D
3/4"	GH4010-12	51010010	35.2
1"	GH4010-16	51010016	43.6
1 1/4"	GH4010-20	51010020	50.2
1 1/2"	GH4010-24	51010024	56.2
2"	GH4010-32	51010032	72.2

Component material: St 52
Other materials by request

HOSES

GS Hose Assembly, Medium Pressure

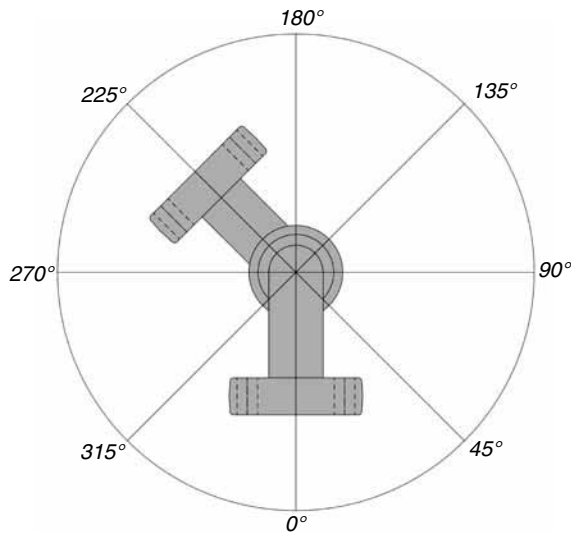

Hose assembly for R1T- and R2T-hoses and GS-SAE high pressure flanges.

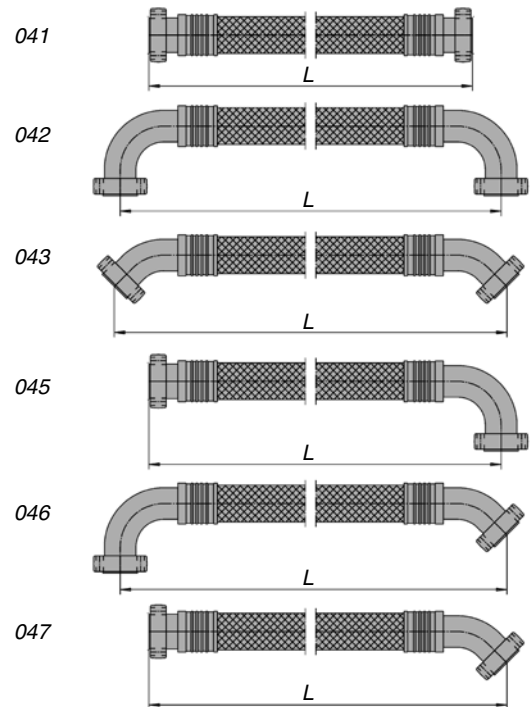

368

SAE 3000 psi Flanges

Size	Part No	Working Pressure (bar)		Bending Radius
		SAE 100 R1T	SAE 100 R2T	
3/4"	M312041-M312047	90	155	180
1"	M316041-M316047	70	140	240
1 1/4"	M320041-M320047	45	110	300
1 1/2"	M324041-M324047	35	85	420
2"	M332041-M332047	25	80	500

SAE 6000 psi Flanges

Size	Part No	Working Pressure (bar)		Bending Radius
		SAE 100 R1T	SAE 100 R2T	
3/4"	M612041-M612047	90	155	180
1"	M616041-M616047	70	140	240
1 1/4"	M620041-M620047	45	110	300
1 1/2"	M624041-M624047	35	85	420
2"	M632041-M632047	25	80	500

Part number does not include bolts

GS-FLANGE SYSTEM
TUBES & PIPES
CLAMPS
VALVES
BITE TYPE FITTINGS
SAE J514 JIC FLARE FITTINGS
HOSES & HOSE COUPLINGS
ADAPTORS
SPECIAL SOLUTIONS
MACHINES
TECHNICAL INFORMATION

Hose Insert – straight

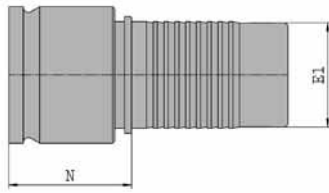

Size	Part No	ID Code	N	E1 (hose I.D.)
3/4"	M12020	5105002710	46	19.1
1"	M16020	5105002716	50	25.4
1 1/4"	M20020	5105002720	52	31.4
1 1/2"	M24020	5105002730	54	38.4
2"	M32020	51050028	59	50.8

Component material: St 52
Other materials by request

Hose Insert – 90°

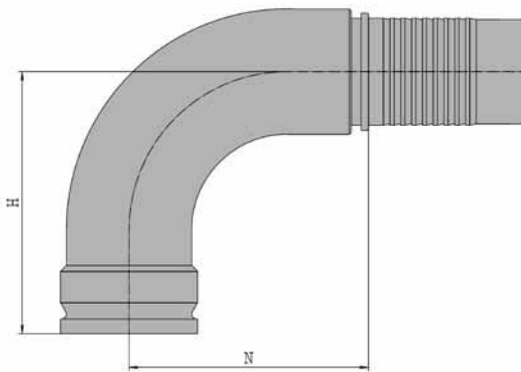

Size	Part No	ID Code	N	H
3/4"	M12021	51050422	59	69
1"	M16021	51050425	71	78
1 1/4"	M20021	510504285	80	88
1 1/2"	M24021	51050437	92	102
2"	M32021	51050446	115	126

Component material: St 52
Other materials by request

Hose Insert – 45°

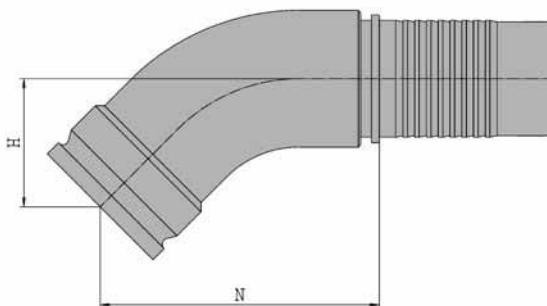

Size	Part No	ID Code	N	H
3/4"	M12022	51050401	78	36
1"	M16022	51050406	89	40
1 1/4"	M20022	51050410	96	43
1 1/2"	M24022	51050413	109	50
2"	M32022	51050418	131	60

Component material: St 52
Other materials by request

369

Hose Tightener and Hose Ferrule

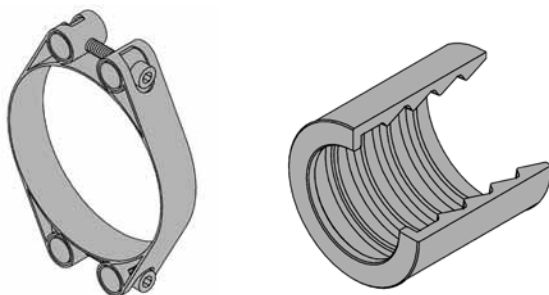

Size	Hose Tightener		Hose Ferrule
	Part No	ID Code	Part No
3/4"	GH2R040	53010004	12MFRx
1"	GH2R050	53010006	16MFRx
1 1/4"	GH2R060	53010008	20MFRx
1 1/2"	GH2R065	53010010	24MFRx
2"	GH2R070	53010014	32MFRx

Component material: St 52
Other materials by request
x = used hose type

HOSES

GS Hose Assembly, Low Pressure

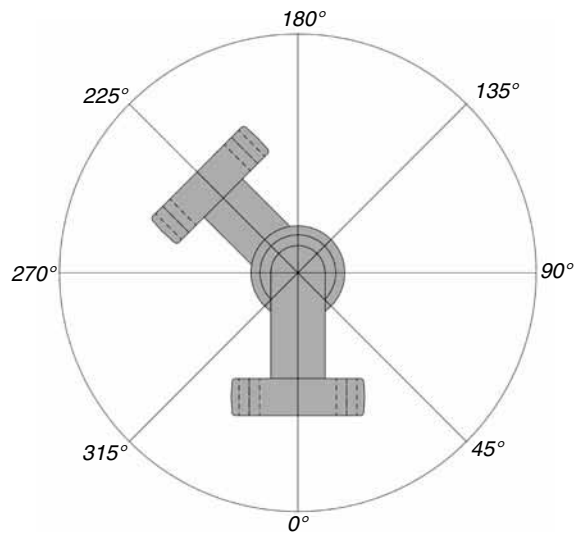

041

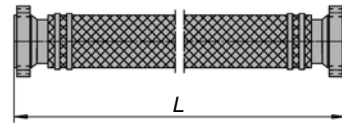

042

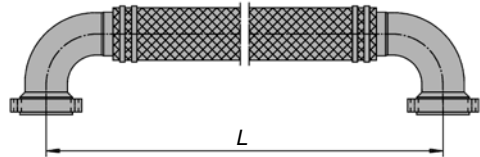

043

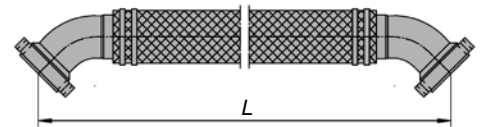

045

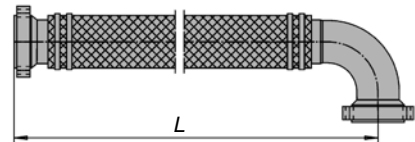

046

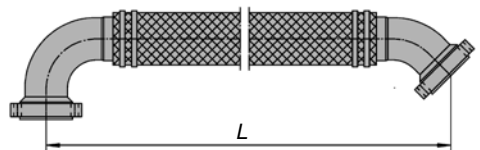

047

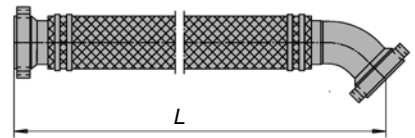

370

Size	Part No	Working Pressure (bar)	Bending Radius
1 1/2"	124041-124047	10	500
2"	132041-132047	10	630
2 1/2"	140041-140047	10	791
3"	148041-148047	10	924
3 1/2"	156041-156047	10	1054
4"	164041-164047	10	1188
5"	180041-180047	10	1452
6"	196041-196047	10	1750
8"	228041-228047	10	1800

Part number does not include bolts

Hose Insert – straight

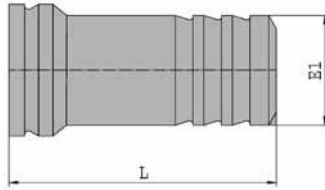

Size	Part No	ID Code	L	E1 (hose I.D.)
1 1/2"	L24020	52050100	110	50.8/2"
2"	L32020	52050104	130	63.5/2½"
2 1/2"	L40020	52050108	150	76.2/3"
3"	L48020	52050112	175	88.9/3¼"
3 1/2"	L56020	52050116	180	101.6/4"
4"	L64020	52050120	190	114/4½"
5"	L80020	52050124	235	127/5"
6"	L96020	52050128	280	152/6"
8"	L28020	52050132	360	205/8"

Hose Insert – 90°

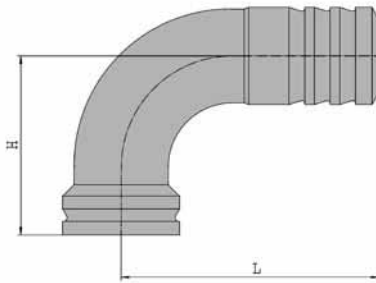

Size	Part No	ID Code	L	H
1 1/2"	L24021	52050420	132	92
2"	L32021	52050428	171	111
2 1/2"	L40021	52050432	210	130
3"	L48021	52050436	250	155
3 1/2"	L56021	52050440	284	174
4"	L64021	52050444	266	193
5"	L80021	52050448	381	236
6"	L96021	52050452	459	279
8"	L28021	52050424	603	365

Hose Insert – 45°

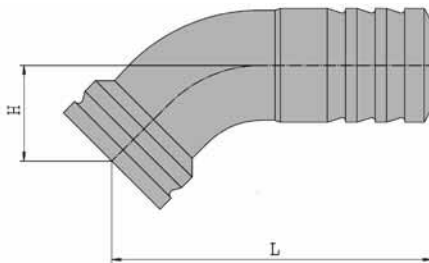

Size	Part No	ID Code	L	H
1 1/2"	L24022	52050400	140	41
2"	L32022	52050404	173	47
2 1/2"	L40022	52050408	207	53
3"	L48022	52050412	245	62
3 1/2"	L56022	52050414	273	68
4"	L64022	52050416	286	72
5"	L80022	52050417	355	88
6"	L96022	52050418	426	103
8"	L28022	52050419	557	134

Hose Tightener and Hose Ferrule

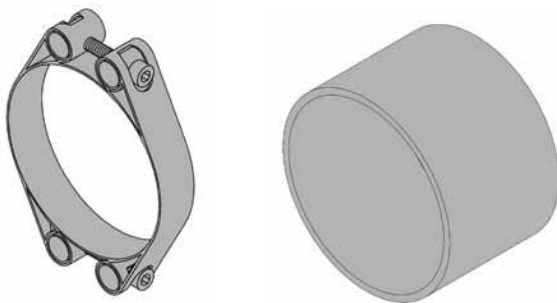

Size	Tightener		Ferrule	
	Part No	ID Code	Part No	ID Code
1 1/2"	GH2R065	53010010	FL24	53011024
2"	GH2R070	53010014	FL32	53011032
2 1/2"	GH2R090	53010016	FL40	53011040
3"	GH2R100	53010018	FL48	53011048
3 1/2"	GH2R110	53010020	FL56	53011056
4"	GH2R125	53010022	FL64	53011064
5"	GH2R150	53010024	FL80	53011080
6"	GH2R180	53010026	FL96	53011096
8"	GH2R220	53010028	FL28	53011028

HOSES

P-Serie Couplings

Ferrules

Hose dim.	Non-Skive Part No	Non-Skive Part No	Non-Skive Part No	Skive Part No	Skive Part No	Skive Part No	Non-Skive Part No	Non-Skive Part No
1/4"	399-04	391-04	392-04	381-04	382-04	493-04	394-04	395-04
5/16"	399-05	391-05	392-05	381-05	382-05	493-05	394-05	395-05
3/8"	399-06	391-06	392-06	381-06	382-06	493-06	394-06	395-06
1/2"	399-08	391-08	392-08	381-08	382-08	493-08	394-08	395-08
5/8"	399-10	391-10	392-10	381-10	382-10	493-10	394-10	395-10
3/4"	399-12	391-12	392-12	381-12	382-12	493-12	394-12	395-12
1"	399-16	391-16	392-16	381-16	382-16	493-16	394-16	395-16
1 1/4"	399-20	391-20	392-20	381-20	382-20	493-20	394-20	395-20
1 1/2"	399-24	391-24	392-24	381-24	382-24	493-24	394-24	395-24
2"	399-32	391-32	392-32	381-32	382-32	493-32	394-32	395-32

372

Choice of Ferrule

Hose type	Ferrule	Skive	Non-skive
P1T-04	394-04		x
P1T-06	394-05		x
P1T-06	394-06		x
G1/1SN-04	399-04		x
G1/1SN-05	399-05		x
G1/1SN-06	399-06		x
G1/1SN-08	399-08		x
G1/1SN-10	399-10		x
G1/1SN-12	399-12		x
G1/1SN-16	399-16		x
G1/1SN-20	381-20	x	
G1/1SN-24	381-24	x	
G1/1SN-32	381-32	x	
C1TA-04	399-04		x
C1TA-05	399-05		x
C1TA-06	399-06		x
C1TA-08	399-08		x
C1TA-10	399-10		x
C1TA-12	399-12		x
C1TA-16	399-16		x
C1TA-20	381-20	x	
G2/2SN-04	399-04		x
G2/2SN-05	399-05		x
G2/2SN-06	399-06		x
G2/2SN-08	399-08		x
G2/2SN-10	399-10		x
G2/2SN-12	399-12		x
G2/2SN-16	399-16		x
G2/2SN-20	382-20	x	
G2/2SN-24	382-24	x	
G2/2SN-32	382-32	x	
CM2T-04	399-04		x
CM2T-05	399-05		x
CM2T-06	399-06		x
CM2T-08	399-08		x
CM2T-10	399-10		x
CM2T-12	399-12		x
CM2T-16	399-16		x
GS2SN-04	399-04		x
GS2SN-06	399-06		x
GS2SN-08	399-08		x
GS2SN-10	399-10		x
GS2SN-12	399-12		x
GS2SN-16	399-16		x
GS2SN-20	382-20	x	
GS2SN-24	382-24	x	
GS2SN-32	382-32	x	
G2L-04	399-04		x
G2L-06	399-06		x
G2L-08	399-08		x
G2L-10	399-10		x
G2L-12	399-12		x
G2L-16	399-16		x
G2L-20	382-20		x

Hose type	Ferrule	Skive	Non-skive
M3K-04	399-04		x
M3K-05	399-05		x
M3K-06	399-06		x
M3K-08	399-08		x
M3K-10	399-10		x
M3K-12	399-12		x
M3K-16	399-16		x
M4K-04	399-04		x
M4K-05	399-05		x
M4K-06	399-06		x
M4K-08	399-08		x
M4K-10	399-10		x
M4K-12	399-12		x
M5K-05	399-04		x
M5K-05	399-05		x
M5K-06	399-06		x
M5K-08	399-08		x
M6K-04	399-04		x
G3K-20	493-20	x	
G3K-24	493-24	x	
G3K-32	493-32	x	
G4K-10	382-10	x	
G4K-12	382-12	x	
G4K-16	382-16	x	
G4K-20	382-20	x	
4SP-04	382-04	x	
4SP-06	382-06	x	
4SP-08	382-08	x	
4SP-10	382-10	x	
4SP-12	382-12	x	
4SP-16	382-16	x	
R7-04	394-04		x
R7-06	394-06		x
R7-08	394-08		x
R7-10	394-10		x
R7-12	394-12		x
R7-16	394-16		x
R8-04	394-04		x
R8-06	394-06		x
R8-08	394-08		x
R8-10	394-10		x
R8-12	394-12		x
R8-16	394-16		x
T9-04	395-04		x
T9-06	395-06		x
T9-08	395-08		x
T9-12	395-12		x
T9-16	395-16		x
G5K-08	392-06	x	
G5K-10	392-08	x	
G5K-12	392-10	x	

HOSES

P-Series couplings (1-4 Wire)

BSP Threads 60° Cone



Conn.	Hose Dia.	Straight female Part No	90° female Part No	45° female Part No	90° compact Part No	Male parallel Part No	Female O-ring Part No	Female flat face Part No
1/8"	1/4"	301-02-04	303-02-04	304-02-04	305-02-04	302-02-04	307-02-04	920-02-04
1/4"	1/4"	301-04-04	303-04-04	304-04-04	305-04-04	302-04-04	307-04-04	920-04-04
3/8"	1/4"	301-06-04	303-06-04	304-06-04	305-06-04	302-06-04	307-06-04	920-06-04
1/4"	3/8"	301-04-06	303-04-06	304-04-06	305-04-06	302-04-06	307-04-06	920-04-06
3/8"	3/8"	301-06-06	303-06-06	304-06-06	305-06-06	302-06-06	307-06-06	920-06-06
1/2"	3/8"	301-08-06	303-08-06	304-08-06	305-08-06	302-08-06	307-08-06	920-08-06
3/8"	1/2"	301-06-08	303-06-08	304-06-08	305-06-08	302-06-08	307-06-08	920-06-08
1/2"	1/2"	301-08-08	303-08-08	304-08-08	305-08-08	302-08-08	307-08-08	920-08-08
3/4"	1/2"	301-12-08	303-12-08	304-12-08	305-12-08	302-12-08	307-12-08	920-12-08
5/8"	5/8"	301-10-10	303-10-10	304-10-10	305-10-10	302-10-10	307-10-10	920-10-10
3/4"	5/8"	301-12-10	303-12-10	304-12-10	305-12-10	302-12-10	307-12-10	920-12-10
3/4"	3/4"	301-12-12	303-12-12	304-12-12	305-12-12	302-12-12	307-12-12	920-12-12
1"	1"	301-16-16	303-16-16	304-16-16	305-16-16	302-16-16	307-16-16	920-16-16
1 1/4"	1 1/4"	301-20-20	303-20-20	304-20-20	305-20-20	302-20-20	307-20-20	920-20-20
1 1/2"	1 1/2"	301-24-24	303-24-24	304-24-24	305-24-24	302-24-24	307-24-24	920-24-24
2"	2"	301-32-32	303-32-32	304-32-32	305-32-32	302-32-32	307-32-32	920-32-32

BSP / NPT

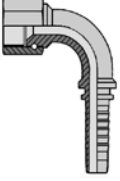
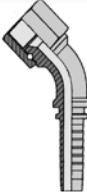

Conn.	Hose Dia.	Male Taper Part No	Banjo BSP Part No	NPT Male Part No
1/8"	1/4"	310-02-04	900-02-04	311-02-04
1/4"	1/4"	310-04-04	900-04-04	311-04-04
3/8"	1/4"	310-06-04	900-06-04	311-06-04
1/4"	3/8"	310-04-06	900-04-06	311-04-06
3/8"	3/8"	310-06-06	900-06-06	311-06-06
1/2"	3/8"	310-08-06	900-08-06	311-08-06
3/8"	1/2"	310-06-08	900-06-08	311-06-08
1/2"	1/2"	310-08-08	900-08-08	311-08-08
3/4"	1/2"	310-12-08	900-12-08	311-12-08
5/8"	5/8"	310-10-10	900-10-10	311-10-10
3/4"	5/8"	310-12-10	900-12-10	311-12-10
3/4"	3/4"	310-12-12	900-12-12	311-12-12
1"	1"	310-16-16	900-16-16	311-16-16
1 1/4"	1 1/4"	310-20-20	900-20-20	311-20-20
1 1/2"	1 1/2"	310-24-24	900-24-24	311-24-24
2"	2"	310-32-32	900-32-32	311-32-32

374

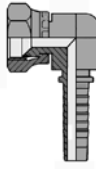
JIC UNF Threads - JIC 74° Cone

						
Conn.	Hose Dia.	Straight Female Part No	90° Female Part No	45° Female Part No	Straight Male Part No	Fem. compact 90° Part No
7/16-20	1/4"	313-07-04	316-07-04	317-07-04	314-07-04	315-07-04
1/2-20	1/4"	313-08-04	316-08-04	317-08-04	314-08-04	315-08-04
9/16-18	1/4"	313-09-04	316-09-04	317-09-04	314-09-04	315-09-04
9/16-18	3/8"	313-09-06	316-09-06	317-09-06	314-09-06	315-09-06
3/4-12	3/8"	313-12-06	316-12-06	317-12-06	314-12-06	315-12-06
3/4-12	1/2"	313-12-08	316-12-08	317-12-08	314-12-08	315-12-08
7/8-14	1/2"	313-14-08	316-14-08	317-14-08	314-14-08	315-14-08
7/8-14	5/8"	313-14-10	316-14-10	317-14-10	314-14-10	315-14-10
1 1/16-12	5/8"	313-17-10	316-17-10	317-17-10	314-17-10	315-17-10
1 1/16-12	3/4"	313-17-12	316-17-12	317-17-12	314-17-12	315-17-12
1 3/16-12	3/4"	313-19-12	316-19-12	317-19-12	314-19-12	315-19-12
1 5/16-12	3/4"	313-21-12	316-21-12	317-21-12	314-21-12	315-21-12
1 5/16-12	1"	313-21-16	316-21-16	317-21-16	314-21-16	315-21-16
1 5/8-12	1"	313-26-16	316-26-16	317-26-16	314-26-16	315-26-16
1 5/8-12	1 1/4"	313-26-20	316-26-20	317-26-20	314-26-20	315-26-20
1 7/8-12	1 1/2"	313-30-24	316-30-24	317-30-24	314-30-24	315-30-24
2 1/2-12	2"	313-40-32	316-40-32	317-40-32	314-40-32	315-40-32

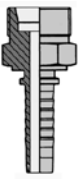
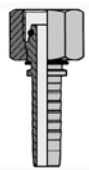
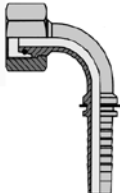

DKOL/SKL Metric (L-Serie)

						
Pipe O.D.	Conn.	Hose Dia.	Male straight Part No	Female O-ring Part No	Female 90° O-ring Part No	Female 45° O-ring Part No
6	12x1,5	1/4"	320-06-04	333-06-04	334-06-04	335-06-04
8	14x1,5	1/4"	320-08-04	333-08-04	334-08-04	335-08-04
10	16x1,5	1/4"	320-10-04	333-10-04	334-10-04	335-10-04
10	16x1,5	3/8"	320-10-06	333-10-06	334-10-06	335-10-06
12	18x1,5	3/8"	320-12-06	333-12-06	334-12-06	335-12-06
15	22x1,5	1/2"	320-15-08	333-15-08	334-15-08	335-15-08
18	26x1,5	1/2"	320-18-08	333-18-08	334-18-08	335-18-08
18	26x1,5	5/8"	320-18-10	333-18-10	334-18-10	335-18-10
22	30x2,0	3/4"	320-22-12	333-22-12	334-22-12	335-22-12
28	36x2,0	1"	320-28-16	333-28-16	334-28-16	335-28-16
35	45x2,0	1 1/4"	320-35-20	333-35-20	334-35-20	335-35-20
42	50x2,0	1 1/2"	320-42-24	333-42-24	334-42-24	335-42-24

HOSES

P-Series couplings (1-4 Wire)

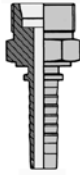
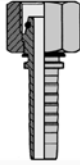
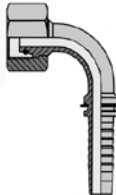
DKOS/SKS Metric (S-Serie)

						
Pipe O.D.	Conn.	Tube Dia.	Male straight Part No	Female O-ring Part No	Female 90° O-ring Part No	Female 45° O-ring Part No
8	16 x 1,5	1/4"	323-08-04	336-08-04	337-08-04	338-08-04
10	18 x 1,5	1/4"	323-10-04	336-10-04	337-10-04	338-10-04
10	18 x 1,5	3/8"	323-10-06	336-10-06	337-10-06	338-10-06
12	20 x 1,5	3/8"	323-12-06	336-12-06	337-12-06	338-12-06
14	22 x 1,5	3/8"	323-14-06	336-14-06	337-14-06	338-14-06
16	24 x 1,5	3/8"	323-16-06	336-16-06	337-16-06	338-16-06
16	24 x 1,5	1/2"	323-16-08	336-16-08	337-16-08	338-16-08
20	30 x 2,0	5/8"	323-20-10	336-20-10	337-20-10	338-20-10
20	30 x 2,0	3/4"	323-20-12	336-20-12	337-20-12	338-20-12
25	36 x 2,0	3/4"	323-25-12	336-25-12	337-25-12	338-25-12
25	36 x 2,0	1"	323-25-16	336-25-16	337-25-16	338-25-16
30	42 x 2,0	1"	323-30-16	336-30-16	337-30-16	338-30-16
38	52 x 2,0	1 1/4"	323-38-20	336-38-20	337-38-20	338-38-20
38	52 x 2,0	1 1/2"	323-38-24	336-38-24	337-38-24	338-38-24

3000 / 6000 psi SAE Flanges with O-Ring

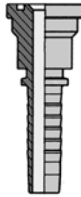
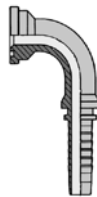
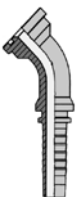
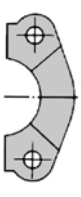
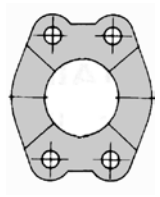
						
Conn.	Hose Dia.	Straight SAE Part No	90° SAE Flange Part No	45° SAE Flange Part No	Splitflange Part No	Monoblock Part No
3000 psi						
1/2"	1/2"	343-08-08	344-08-08	345-08-08	943-08-08	945-08-08
3/4"	3/4"	343-12-12	344-12-12	345-12-12	943-12-12	945-12-12
1"	3/4"	343-16-12	344-16-12	345-16-12	943-16-12	945-16-12
1"	1"	343-16-16	344-16-16	345-16-16	943-16-16	945-16-16
1 1/4"	1"	343-20-16	344-20-16	345-20-16	943-20-16	945-20-16
1 1/4"	1 1/4"	343-20-20	344-20-20	345-20-20	943-20-20	945-20-20
1 1/2"	1 1/4"	343-24-20	344-24-20	345-24-20	943-24-20	945-24-20
1 1/2"	1 1/2"	343-24-24	344-24-24	345-24-24	943-24-24	945-24-24
2"	1 1/2"	343-32-24	344-32-24	345-32-24	943-32-24	945-32-24
2"	2"	343-32-32	344-32-32	345-32-32	943-32-32	945-32-32
6000 psi						
1/2"	1/2"	346-08-08	347-08-08	348-08-08	944-08-08	946-08-08
3/4"	3/4"	346-12-12	347-12-12	348-12-12	944-12-12	946-12-12
1"	3/4"	346-16-12	347-16-12	348-16-12	944-16-12	946-16-12
1"	1"	346-16-16	347-16-16	348-16-16	944-16-16	946-16-16
1 1/4"	1"	346-20-16	347-20-16	348-20-16	944-20-16	946-20-16
1 1/4"	1 1/4"	346-20-20	347-20-20	348-20-20	944-20-20	946-20-20
1 1/2"	1 1/4"	346-24-20	347-24-20	348-24-20	944-24-20	946-24-20
1 1/2"	1 1/2"	346-24-24	347-24-24	348-24-24	944-24-24	946-24-24
2"	1 1/2"	346-32-24	347-32-24	348-32-24	944-32-24	946-32-24
2"	2"	346-32-32	347-32-32	348-32-32	944-32-32	946-32-32

376

JIS - Komatsu - Banjo - Kobelco - Kärcher

Conn.	Hose Dia.	JIS Japanese Part	JIS Komatsu Part No	Kobelco mm Part No	Kärcher Part No	Banjo mm Part No
1/8"	1/4"	712-02-04	335-02-04	324-02-04	330-02-04	901-02-04
1/4"	1/4"	712-04-04	335-04-04	324-04-04	330-04-04	901-04-04
3/8"	1/4"	712-06-04	335-06-04	324-06-04	330-06-04	901-06-04
3/8"	3/8"	712-06-06	335-06-06	324-06-06	330-06-06	901-06-06
1/2"	3/8"	712-08-06	335-08-06	324-08-06	330-08-06	901-08-06
1/2"	1/2"	712-08-08	335-08-08	324-08-08	330-08-08	901-08-08
3/4"	3/4"	712-12-12	335-12-12	324-12-12	330-12-12	901-12-12
1"	1"	712-16-16	335-16-16	324-16-16	330-16-16	901-16-16
1 1/4"	1 1/4"	712-20-20	335-20-20	324-20-20	330-20-20	901-20-20
1 1/2"	1 1/2"	712-24-24	335-24-24	324-24-24	330-24-24	901-24-24
2"	2"	712-32-32	335-32-32	324-32-32	330-32-32	901-32-32
14 x 1,5	1/4"	712-04-04	335-04-04	324-04-04	330-04-04	901-04-04
18 x 1,5	3/8"	712-06-06	335-06-06	324-06-06	330-06-06	901-06-06
22 x 1,5	1/2"	712-08-08	335-08-08	324-08-08	330-08-08	901-08-08
30 x 1,5	3/4"	712-12-12	335-12-12	324-12-12	330-12-12	901-12-12
33 x 2,0	1"	712-16-16	335-16-16	324-16-16	330-16-16	901-16-16
10 x 1,0	1/4"	712-02-04	335-02-04	324-02-04	330-02-04	901-02-04
12 x 1,5	1/4"	712-04-04	335-04-04	324-04-04	330-04-04	901-04-04
14 x 1,5	1/4"	712-05-04	335-05-04	324-05-04	330-05-04	901-05-04
16 x 1,5	3/8"	712-06-06	335-06-06	324-06-06	330-06-06	901-06-06
18 x 1,5	3/8"	712-08-06	335-08-06	324-08-06	330-08-06	901-08-06
18 x 1,5	1/2"	712-08-08	335-08-08	324-08-08	330-08-08	901-08-08
22 x 1,5	1/4"	712-14-04	335-14-04	324-14-04	330-14-04	901-14-04
22 x 1,5	5/16"	712-14-05	335-14-05	324-14-05	330-14-05	901-14-05
22 x 1,5	3/8"	712-14-06	335-14-06	324-14-06	330-14-06	901-14-06
30 x 1,5	5/8"	712-10-22	335-10-22	324-10-22	330-10-22	901-10-22
36 x 1,5	3/4"	712-12-28	335-12-28	324-12-28	330-12-28	901-12-28
36 x 1,5	1"	712-16-28	335-16-28	324-16-28	330-16-28	901-16-28

ORFS / SAE Flat Face O-Ring

Conn.	Hose Dia.	ORFS Male Part No	ORFS Female Part No	ORFS 45° Part No	ORFS 90° Part No
9/16"-18	1/4"	360-04-04	361-04-04	362-04-04	363-04-04
1 1/16"-16	1/4"	360-06-04	361-06-04	362-06-04	363-06-04
1 1/16"-16	5/16"	360-06-05	361-06-05	362-06-05	363-06-05
1 1/16"-16	3/8"	360-06-06	361-06-06	362-06-06	363-06-06
1 3/16"-16	3/8"	360-08-06	361-08-06	362-08-06	363-08-06
1 3/16"-16	1/2"	360-08-08	361-08-08	362-08-08	363-08-08
1" -14	1/2"	360-10-08	361-10-08	362-10-08	363-10-08
1" -14	5/8"	360-10-10	361-10-10	362-10-10	363-10-10
1 3/16"-12	5/8"	360-12-10	361-12-10	362-12-10	363-12-10
1 3/16"-12	3/4"	360-12-12	361-12-12	362-12-12	363-12-12
1 7/16"-12	3/4"	360-16-12	361-16-12	362-16-12	363-16-12
1 7/16"-12	1"	360-16-16	361-16-16	362-16-16	363-16-16

HOSES

I-Serie Interlock Couplings (4 - 6 Spiral)

SAE 3000 psi with O-Ring

Conn.	Hose Dia.	Straight SAE flange Part No	90° SAE flange Part No	45° SAE flange Part No	Splitflange Part No	Monoblock Part No
3/4"	3/4"	543-12-12	544-12-12	545-12-12	943-12-12	945-12-12
1"	1"	543-16-16	544-16-16	545-16-16	943-16-16	945-16-16
1 1/4"	1"	543-20-16	544-20-16	545-20-16	943-20-16	945-20-16
1 1/4"	1 1/4"	543-20-20	544-20-20	545-20-20	943-20-20	945-20-20
1 1/2"	1 1/4"	543-24-20	544-24-20	545-24-20	943-24-20	945-24-20
1 1/2"	1 1/2"	543-24-24	544-24-24	545-24-24	943-24-24	945-24-24
2"	1 1/2"	543-32-24	544-32-24	545-32-24	943-32-24	945-32-24
2"	2"	543-32-32	544-32-32	545-32-32	943-32-32	945-32-32
1 1/2"	2"	543-24-32	543-24-32	545-24-32	943-24-32	945-24-32

SAE 6000 psi with O-Ring

Conn.	Hose Dia.	Straight SAE flange Part No	90° SAE flange Part No	45° SAE flange Part No	Splitflange Part No	Monoblock Part No
3/4"	3/4"	546-12-12	547-12-12	548-12-12	944-12-12	946-12-12
1"	1"	546-16-16	547-16-16	548-16-16	944-16-16	946-16-16
1 1/4"	1"	546-20-16	547-20-16	548-20-16	944-20-16	946-20-16
1 1/4"	1 1/4"	546-20-20	547-20-20	548-20-20	944-20-20	946-20-20
1 1/2"	1 1/4"	546-24-20	547-24-20	548-24-20	944-24-20	946-24-20
1 1/2"	1 1/2"	546-24-24	547-24-24	548-24-24	944-24-24	946-24-24
2"	1 1/2"	546-32-24	547-32-24	548-32-24	944-32-24	946-32-24
2"	2"	546-32-32	547-32-32	548-32-32	944-32-32	946-32-32
1 1/2"	2"	546-24-32	547-24-32	548-24-32	944-24-32	946-24-32

378

I-Serie Interlock Couplings (4-6 Spiral)

Ferrules - BSP and NPT Couplings

Conn.	Hose Dia.	4-spiral ferrule Part No	6-spiral ferrule Part No	Female O-ring Part No	90° Fem. O-ring Part No	45° Fem. O-ring Part No	NPT Male Part No
3/4"	3/4"	594-12-12	596-12-12	501-12-12	503-12-12	504-12-12	511-12-12
1"	1"	594-16-16	596-16-16	501-16-16	503-16-16	504-16-16	511-16-16
1 1/4"	1 1/4"	594-20-20	596-20-20	501-20-20	503-20-20	504-20-20	511-20-20
1 1/2"	1 1/2"	594-24-24	596-24-24	501-24-24	503-24-24	504-24-24	511-24-24
2"	2"	594-32-32	596-32-32	501-32-32	503-32-32	504-32-32	511-32-32

JIC Couplings

Conn.	Hose Dia.	Female straight Part No	Male straight Part No	Female 90° Part No	Female 45° Part No
1 1/16-12	3/4"	513-17-12	514-17-12	516-17-12	517-17-12
1 5/16-12	1"	513-21-16	514-21-16	516-21-16	517-21-16
1 5/8-12	1 1/4"	513-26-20	514-26-20	516-26-20	517-26-20
1 7/8-12	1 1/2"	513-30-24	514-30-24	516-30-24	517-30-24
2 1/2-12	2"	513-40-32	514-40-32	516-40-32	517-40-32

DKOS / SKS Metric

Pipe O.D.	Conn.	Hose Dia.	Male straight Part No	Female O-ring Part No	Female 90° O-ring Part No	Female 45° O-ring Part No
20	30 x 2	3/4"	523-20-12	536-20-12	537-20-12	538-20-12
25	36 x 2	3/4"	523-25-12	536-25-12	537-25-12	538-25-12
25	36 x 2	1"	523-25-16	536-25-16	537-25-16	538-25-16
30	42 x 2	1"	523-30-16	536-30-16	537-30-16	538-30-16
38	52 x 2	1 1/4"	523-38-20	536-38-20	537-38-20	538-38-20
38	52 x 2	1 1/2"	523-38-24	536-38-24	537-38-24	538-38-24

HOSES

G-Serie One Piece Couplings

Choice of Couplings

Following hosetypes / dimensions fits with G-couplings.

Hose Type / Dim.
G1-04
G1-05
G1-06
G1-08
G1-10
G1-12
G1-16
G1-20
G1-24
G1-32
G2-04
G2-05
G2-06
G2-08
G2-10
G2-12
G2-16
G2-20
G2-24
G2-32
CM2T-04
CM2T-05
CM2T-06
CM2T-08
CM2T-10
CM2T-12
CM2T-16
GL-04
GL-06
GL-08
GL-10
GL-12
GL-16
GL-20
C1TH-04
C1TH-05
C1TH-06
C1TH-08
C1TH-10
C1TH-12
C1TH-16
C1TH-20
C1TH-24
1PW-05
1PW-06
1PW-08

Hose Type / Dim.
2PW-05
2PW-06
2PW-08
M3K-04
M3K-05
M3K-06
M3K-10
M3K-12
M3K-16
M4K-04
M4K-05
M4K-06
M4K-08
M4K-10
M4K-12
M5K-04
M5K-05
M5K-06
M5K-08
M6K-04
R7-04
R7-06
R7-08
R7-10
R7-12
R7-16
R8-04
R8-06
R8-08
R8-10
R8-12
R8-16
T9-04
T9-06
T9-08
T9-10
T9-12

Hose Type / Dim.
GP40-04
GP40-05
GP40-06
GP40-08
GP40-12
GP40-16
GP40-20
GP40-24
GP60-04
GP60-05
GP60-06
GP60-08
GP60-10
GP60-12
GP60-16
GP80-04
GP80-05
GP80-06
GP80-08
GP80-10
GP80-12
GP80-16
GP80-20
GP80-24
GP80-32
AF-04
AF-06
AF-08
AF-10
AF-12
AF-16
AF-20
AF-24
PF-04
PF-06
PF-08
PF-10
PF-12
PF-16
PF-20
PF-24
ACR-16
ACR-20
ACR-24
ACR-32
MEGA-12
MEGA-16
MEGA-20
MEGA-24
MEGA-32

380

BSP Threads 60° Cone

Conn.	Hose Dia.	Straight female		90° female		45° female		90° compact	
		Part No	B	Part No	B	Part No	B	Part No	B
		1/8"	1/4"	G301-02-04	18,0	G303-02-04	-	G304-02-04	-
1/4"	1/4"	G301-04-04	22,0	G303-04-04	26,5	G304-04-04	31,1	G305-04-04	18,2
3/8"	1/4"	G301-06-04	26,0	G303-06-04	24,5	G304-06-04	37,1	G305-06-04	20,0
1/4"	3/8"	G301-04-06	x	G303-04-06	-	G304-04-06	-	G305-04-06	-
3/8"	3/8"	G301-06-06	25,3	G303-06-06	34,0	G304-06-06	39,1	G305-06-06	20,0
1/2"	3/8"	G301-08-06	26,8	G303-08-06	32,2	G304-08-06	43,0	G305-08-06	23,5
3/8"	1/2"	G301-06-08	29,0	G303-06-08	-	G304-06-08	-	G305-06-08	-
1/2"	1/2"	G301-08-08	26,7	G303-08-08	40,5	G304-08-08	44,0	G305-08-08	23,5
3/4"	1/2"	G301-12-08	32,0	G303-12-08	-	G304-12-08	-	G305-12-08	-
5/8"	5/8"	G301-10-10	31,0	G303-10-10	46,6	G304-10-10	52,1	G305-10-10	24,9
3/4"	5/8"	G301-12-10	32,0	G303-12-10	46,6	G304-12-10	62,0	G305-12-10	-
3/4"	3/4"	G301-12-12	32,0	G303-12-12	56,0	G304-12-12	64,4	G305-12-12	27,0
1"	1"	G301-16-16	39,2	G303-16-16	74,3	G304-16-16	78,8	G305-16-16	34,6
1 1/4"	1 1/4"	G301-20-20	41,5	G303-20-20	82,8	G304-20-20	93,4	G305-20-20	-
1 1/2"	1 1/2"	G301-24-24	36,1	G303-24-24	77,6	G304-24-24	72,7	G305-24-24	-
2"	2"	G301-32-32	36,6	G303-32-32	97,8	G304-32-32	-	G305-32-32	-

- = Not available

BSP / NPT

Conn.	Hose Dia.	Male parallel		G920-Female flat face		G310-Male taper		G900-Banjo BSP		G311-NPT Male	
		Part No	B	Part No	B	Part No	B	Part No	B	Part No	B
		1/8"	1/4"	G302-02-04	18,0	G920-02-04	-	G310-02-04	-	G900-02-04	-
1/4"	1/4"	G302-04-04	22,0	G920-04-04	-	G310-04-04	24,8	G900-04-04	30,3	G311-04-04	26,5
3/8"	1/4"	G302-06-04	26,0	G920-06-04	-	G310-06-04	26,0	G900-06-04	32,2	G311-06-04	28,0
1/4"	3/8"	G302-04-06	-	G920-04-06	-	G310-04-06	-	G900-04-06	30,6	G311-04-06	30,1
3/8"	3/8"	G302-06-06	25,3	G920-06-06	18,1	G310-06-06	26,1	G900-06-06	32,4	G311-06-06	27,6
1/2"	3/8"	G302-08-06	26,8	G920-08-06	17,6	G310-08-06	30,9	G900-08-06	34,8	G311-08-06	34,6
3/8"	1/2"	G302-06-08	29,0	G920-06-08	-	G310-06-08	27,0	G900-06-08	-	G311-06-08	28,5
1/2"	1/2"	G302-08-08	26,7	G920-08-08	18,0	G310-08-08	30,9	G900-08-08	38,2	G311-08-08	34,0
3/4"	1/2"	G302-12-08	32,0	G920-12-08	-	G310-12-08	-	G900-12-08	-	G311-12-08	36,5
5/8"	5/8"	G302-10-10	31,0	G920-10-10	-	G310-10-10	32,4	G900-10-10	-	G311-10-10	-
3/4"	5/8"	G302-12-10	32,0	G920-12-10	-	G310-12-10	-	G900-12-10	-	G311-12-10	36,0
3/4"	3/4"	G302-12-12	32,0	G920-12-12	-	G310-12-12	35,7	G900-12-12	-	G311-12-12	37,0
1"	1"	G302-16-16	39,2	G920-16-16	-	G310-16-16	41,6	G900-16-16	-	G311-16-16	47,7
1 1/4"	1 1/4"	G302-20-20	41,5	G920-20-20	-	G310-20-20	-	G900-20-20	-	G311-20-20	53,0
1 1/2"	1 1/2"	G302-24-24	47,1	G920-24-24	-	G310-24-24	-	G900-24-24	-	G311-24-24	47,4
2"	2"	G302-32-32	55,4	G920-32-32	-	G310-32-32	55,4	G900-32-32	-	G311-32-32	51,8

- = Not available

HOSES

G-Series One Piece Couplings

JIC - UNF Threads - JIC 74° Cone

Conn.	Hose Dia.	Straight Female		90° Female		45° Female		Straight Male	
		Part No	B	Part No	B	Part No	B	Part No	B
		7/16-20	1/4"	G313-07-04	18,4	G316-07-04	26,2	G317-07-04	32,0
1/2-20	1/4"	G313-08-04	20,5	G316-08-04	29,2	G317-08-04	39,0	G314-08-04	29,5
9/16-18	1/4"	G313-09-04	20,5	G316-09-04	38,0	G317-09-04	43,3	G314-09-04	26,5
9/16-18	3/8"	G313-09-06	21,1	G316-09-06	32,1	G317-09-06	46,0	G314-09-06	29,6
3/4-12	3/8"	G313-12-06	23,6	G316-12-06	36,5	G317-12-06	45,2	G314-12-06	30,6
3/4-12	1/2"	G313-12-08	19,5	G316-12-08	36,6	G317-12-08	46,6	G314-12-08	30,5
7/8-14	1/2"	G313-14-08	24,0	G316-14-08	43,9	G317-14-08	54,4	G314-14-08	33,0
7/8-14	5/8"	G313-14-10	26,0	G316-14-10	43,5	G317-14-10	54,0	G314-14-10	38,5
1 1/16-12	5/8"	G313-17-10	26,0	G316-17-10	47,5	G317-17-10	67,5	G314-17-10	38,0
1 1/16-12	3/4"	G313-17-12	27,5	G316-17-12	46,2	G317-17-12	73,2	G314-17-12	42,5
1 3/16-12	3/4"	G313-19-12	26,0	G316-19-12	73,0	G317-19-12	-	G314-19-12	40,0
1 5/16-12	3/4"	G313-21-12	29,0	G316-21-12	-	G317-21-12	95,0	G314-21-12	45,0
1 5/16-12	1"	G313-21-16	33,2	G316-21-16	58,1	G317-21-16	77,8	G314-21-16	47,7
1 5/8-12	1"	G313-26-16	36,2	G316-26-16	110,2	G317-26-16	-	G314-26-16	52,2
1 5/8-12	1 1/4"	G313-26-20	40,5	G316-26-20	79,0	G317-26-20	110,0	G314-26-20	53,5
1 7/8-12	1 1/2"	G313-30-24	27,9	G316-30-24	77,6	G317-30-24	-	G314-30-24	-
2 1/2-12	2"	G313-40-32	31,2	G316-40-32	-	G317-40-32	-	G314-40-32	-

- = Not available

DKOL / SKL - Metric - (L-Serie) - Standpipe

Pipe Dia.	Conn.	Hose Dia.	Male straight		Female O-ring		Female 90° O-ring		Female 45° O-ring		Standpipe	
			Part No	B	Part No	B	Part No	B	Part No	B	Part No	B
			6	12 x 1,5	1/4"	G320-06-04	19,8	G333-06-04	25,8	G334-06-04	31,5	G335-06-04
8	14 x 1,5	1/4"	G320-08-04	20,8	G333-08-04	28,4	G334-08-04	31,5	G335-08-04	36,5	G339-08-04	36,5
10	16 x 1,5	1/4"	G320-10-04	21,8	G333-10-04	29,3	G334-10-04	31,5	G335-10-04	38,3	G339-10-04	38,5
10	16 x 1,5	3/8"	G320-10-06	21,9	G333-10-06	29,2	G334-10-06	32,2	G335-10-06	40,5	G339-10-06	38,6
12	18 x 1,5	3/8"	G320-12-06	22,9	G333-12-06	29,9	G334-12-06	32,2	G335-12-06	40,9	G339-12-06	38,6
15	22 x 1,5	1/2"	G320-15-08	24,0	G333-15-08	29,3	G334-15-08	40,4	G335-15-08	47,1	G339-15-08	38,6
18	26 x 1,5	1/2"	G320-18-08	25,5	G333-18-08	30,3	G334-18-08	44,0	G335-18-08	57,2	G339-18-08	-
18	26 x 1,5	5/8"	G320-18-10	25,0	G333-18-10	30,3	G334-18-10	47,6	G335-18-10	56,0	G339-18-10	-
22	30 x 2,0	3/4"	G320-22-12	27,0	G333-22-12	32,3	G334-22-12	56,3	G335-22-12	66,1	G339-22-12	-
28	36 x 2,0	1"	G320-28-16	30,4	G333-28-16	36,7	G334-28-16	74,3	G335-28-16	78,8	G339-28-16	-
35	45 x 2,0	1 1/4"	G320-35-20	35,1	G333-35-20	44,1	G334-35-20	82,2	G335-35-20	93,4	G339-35-20	-
42	50 x 2,0	1 1/2"	G320-42-24	36,2	G333-42-24	45,6	G334-42-24	93,6	G335-42-24	93,6	G339-42-24	-

- = Not available

DKOS / SKS - Metric – S-Serie

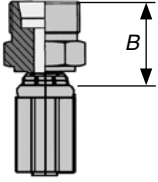
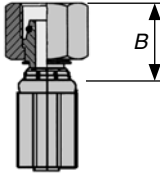
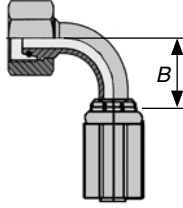
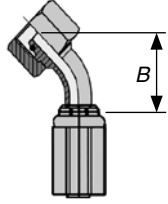
										
Pipe O.D.	Conn.	Hose Dia.	Male straight		Female O-ring		Female 90° O-ring		Female 45° O-ring	
			Part No	B	Part No	B	Part No	B	Part No	B
6	14 x 1,5	1/4"	G323-06-04	-	G336-06-04	25,8	G337-06-04	-	G338-06-04	-
8	16 x 1,5	1/4"	G323-08-04	27,0	G336-08-04	28,4	G337-08-04	31,5	G338-08-04	36,5
10	18 x 1,5	1/4"	G323-10-04	26,5	G336-10-04	29,3	G337-10-04	31,5	G338-10-04	38,3
10	18 x 1,5	3/8"	G323-10-06	27,1	G336-10-06	29,2	G337-10-06	32,2	G338-10-06	40,5
12	20 x 1,5	3/8"	G323-12-06	29,6	G336-12-06	29,9	G337-12-06	32,2	G338-12-06	40,9
14	22 x 1,5	3/8"	G323-14-06	31,6	G336-14-06	32,5	G337-14-06	32,2	G338-14-06	43,0
16	24 x 1,5	3/8"	G323-16-06	-	G336-16-06	-	G337-16-06	-	G338-16-06	-
16	24 x 1,5	1/2"	G323-16-08	31,5	G336-16-08	33,6	G337-16-08	40,4	G338-16-08	48,5
20	30 x 2,0	5/8"	G323-20-10	36,0	G336-20-10	38,2	G337-20-10	46,6	G338-20-10	55,7
20	30 x 2,0	3/4"	G323-20-12	33,9	G336-20-12	37,5	G337-20-12	49,3	G338-20-12	-
25	36 x 2,0	3/4"	G323-25-12	41,0	G336-25-12	42,6	G337-25-12	56,3	G338-25-12	67,6
25	36 x 2,0	1"	G323-25-16	40,4	G336-25-16	45,7	G337-25-16	-	G338-25-16	-
30	42 x 2,0	1"	G323-30-16	42,4	G336-30-16	49,2	G337-30-16	74,3	G338-30-16	83,0
38	52 x 2,0	1 1/4"	G323-38-20	40,1	G336-38-20	57,8	G337-38-20	-	G338-38-20	-
38	52 x 2,0	1 1/2"	G323-38-24	-	G336-38-24	-	G337-38-24	-	G338-38-24	-

- = Not available

3000 psi – SAE Flanges with O-Ring

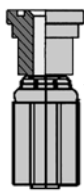
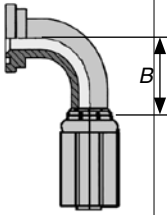
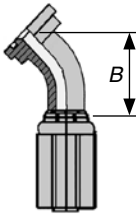
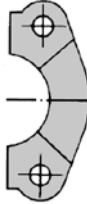
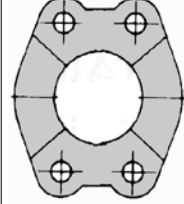
											
Conn.	Hose Dia.	Straight SAE		90° SAE Flange		45° SAE Flange		Splitflange	Monoblock		
		Part No	B	Part No	B	Part No	B				
1/2"	1/2"	G343-08-08	42,5	G344-08-08	53,7	G345-08-08	-	-	-		
3/4"	3/4"	G343-12-12	47,0	G344-12-12	60,7	G345-12-12	67,5	G943-12-12	G945-12-12		
1"	3/4"	G343-16-12	37,8	G344-16-12	60,7	G345-16-12	67,5	-	-		
1"	1"	G343-16-16	39,2	G344-16-16	71,3	G345-16-16	72,9	G943-16-16	G945-16-16		
1 1/4"	1"	G343-20-16	39,2	G344-20-16	71,3	G345-20-16	72,7	-	-		
1 1/4"	1 1/4"	G343-20-20	53,5	G344-20-20	78,5	G345-20-20	83,0	G943-20-20	G945-20-20		
1 1/2"	1 1/4"	G343-24-20	58,5	G344-24-20	-	G345-24-20	-	-	-		
1 1/2"	1 1/2"	G343-24-24	33,0	G344-24-24	77,6	G345-24-24	77,8	G943-24-24	G945-24-24		
2"	1 1/2"	G343-32-24	35,0	G344-32-24	77,6	G345-32-24	78,5	-	-		
2"	2"	G343-32-32	69,0	G344-32-32	97,8	G345-32-32	104,0	G943-32-32	G945-32-32		

- = Not available

HOSES

G-Serie One Piece Couplings

Powerwash

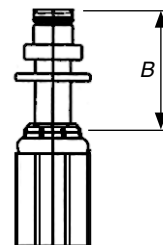
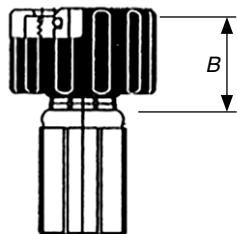

Hose	Dia.	Powerwash swivel female		Powerwash w/O-ring	
		Part No	B	Part No	B
10	1/4"	PW-0410KO	36,5	GPW-0410KO	-
10	5/18"	PW-0510KO	36,5	GPW-0510KO	-
11	5/16"	PW-0511KO	39,5	GPW-0511KO	-
10	3/8"	PW-0610KO	36,6	GPW-0610KO	-
11	3/8"	PW-0611KO	39,6	GPW-0611KO	-
M22 X 1,5	1/4"	PW-0415KR	-	GPW-0415KR	28
M22 X 1,5	5/16"	PW-0515KR	-	GPW-0515KR	27,5
M22 X 1,5	3/8"	PW-0615KR	-	GPW-0615KR	27,5

- = Not available

384

Ferrules

Hose Dia.	G3K-G4K		G596-G5K-G6K		G599-G3K-G4K-G5K-G6K	
	Part No	B	Part No	B	Part No	B
3/8"	G594-06	-	G596-06	-	G599-06	31,8
1/2"	G594-08	-	G596-08	-	G599-08	34,4
5/8"	G594-10	-	G596-10	-	G599-10	41,7
3/4"	G594-12	-	G596-12	-	G599-12	45,7
1"	G594-16	-	G596-16	-	G599-16	52,6
1 1/4"	G594-20	61,5	G596-20	67,8	G599-20	-
1 1/2"	G594-24	-	G596-24	-	G599-24	74,7
2"	G594-32	-	G596-32	-	G599-32	87,6

- = Not available

Inserts – BSP 60° Cone

Conn.	Hose Dia.	Male parallel		G501-Female O-ring		G503-Female 90° O-ring		G504-Female 45° O-ring		G511-NPT Male	
		Part No	B	Part No	B	Part No	B	Part No	B	Part No	B
3/8"	3/8"	G502-06-06	27,2	G501-06-06	23,5	G503-06-06	42,2	G504-06-06	46,3	G511-06-06	33,2
1/2"	1/2"	G502-08-08	30,0	G501-08-08	23,5	G503-08-08	50,2	G504-08-08	54,1	G511-08-08	36,5
5/8"	5/8"	G502-10-10	33,7	G501-10-10	30,2	G503-10-10	62,2	G504-10-10	67,7	G511-10-10	-
3/4"	3/4"	G502-12-12	34,7	G501-12-12	34,0	G503-12-12	75,0	G504-12-12	83,4	G511-12-12	39,0
1"	1"	G502-16-16	41,2	G501-16-16	38,6	G503-16-16	94,6	G504-16-16	99,1	G511-16-16	49,2
1 1/4"	1 1/4"	G502-20-20	47,9	G501-20-20	45,4	G503-20-20	109,4	G504-20-20	119,9	G511-20-20	55,8
1 1/2"	1 1/2"	G502-24-24	45,7	G501-24-24	46,2	G503-24-24	118,8	G504-24-24	138,7	G511-24-24	48,7
2"	2"	G502-32-32	-	G501-32-32	-	G503-32-32	-	G504-32-32	-	G511-32-32	65,0

- = Not available

HOSES

GS-Serie Couplings

Inserts – UNF JIC 74° Seat

Conn.	Hose Dia.	Female straight		Male straight		Female 90°		Female 45°	
		Part No	B	Part No	B	Part No	B	Part No	B
		3/4	3/8"	G513-12-06	24,3	G514-12-06	34,2	G516-12-06	55,2
7/8	1/2"	G513-14-08	24,5	G514-14-08	37,5	G516-14-08	54,5	G517-14-08	53,5
11/16	5/8"	G513-17-10	29,7	G514-17-10	43,7	G516-17-10	70,7	G517-17-10	71,7
11/16	3/4"	G513-17-12	32,2	G514-17-12	42,0	G516-17-12	62,0	G517-17-12	79,0
15/16	3/4"	G513-21-12	34,4	G514-21-12	45,0	G516-21-12	64,0	G517-21-12	86,0
15/16	1"	G513-21-16	36,2	G514-21-16	47,2	G516-21-16	87,6	G517-21-16	95,7
15/8	1"	G513-26-16	41,8	G514-26-16	51,7	G516-26-16	97,6	G517-26-16	107,6
15/8	1 1/4"	G513-26-20	48,1	G514-26-20	53,9	G516-26-20	102,9	G517-26-20	102,7
17/8	1 1/2"	G513-30-24	48,3	G514-30-24	51,7	G516-30-24	118,8	G517-30-24	123,4
2 1/2	2"	G513-40-32	54,9	G514-40-32	69,3	G516-40-32	-	G517-40-32	-

- = Not available

Inserts – DKOS / SKS Metric

Pipe O.D.	Conn.	Hose Dia.	Male straight		Female O-ring		Female 90° O-ring		Female 45° O-ring	
			Part No	B	Part No	B	Part No	B	Part No	B
			12	20 x 1,5	3/8"	G523-12-06	27,9	G536-12-06	37,2	G537-12-06
16	24 x 1,5	1/2"	G523-16-08	30,0	G536-16-08	41,5	G537-16-08	50,5	G538-16-08	58,7
20	30 x 2	5/8"	G523-20-10	34,7	G536-20-10	49,7	G537-20-10	62,2	G538-20-10	71,3
20	30 x 2	3/4"	G523-20-12	34,0	G536-20-12	52,0	G537-20-12	72,5	G538-20-12	109,9
25	36 x 2	3/4"	G523-25-12	38,0	G536-25-12	56,4	G537-25-12	75,0	G538-25-12	86,3
25	36 x 2	1"	G523-25-16	40,2	G536-25-16	59,6	G537-25-16	94,6	G538-25-16	103,4
30	42 x 2	1"	G523-30-16	42,2	G536-30-16	61,6	G537-30-16	94,6	G538-30-16	103,4
38	52 x 2	1 1/4"	G523-38-20	51,9	G536-38-20	73,9	G537-38-20	109,4	G538-38-20	124,9
38	52 x 2	1 1/2"	G523-38-24	-	G536-38-24	73,7	G537-38-24	-	G538-38-24	-

- = Not available

SAE 3000 psi with O-Ring

Hose Dia.	Straight SAE fl.		90° SAE fl.		45° SAE fl.		Split flange	Monoblock
	Part No	B	Part No	B	Part No	B	Part No	Part No
	1/2"	G543-08-08	55,5	G544-08-08	50,5	G545-08-08	56,5	G943-08-08
5/8"	G543-12-10	58,7	G544-12-10	59,7	G545-12-10	76,7	-	-
3/4"	G543-12-12	60,0	G544-12-12	61,0	G545-12-12	73,0	G943-12-12	G945-12-12
3/4"	G543-16-12	60,0	G544-16-12	77,0	G545-16-12	75,0	-	-
1"	G543-16-16	68,6	G544-16-16	78,6	G545-16-16	90,6	G943-16-16	G945-16-16
1"	G543-20-16	68,2	G544-20-16	76,8	G545-20-16	100,8	-	-
1 1/4"	G543-20-20	74,9	G544-20-20	94,9	G545-20-20	98,9	G943-20-20	G945-20-20
1 1/4"	G543-24-20	88,9	G544-24-20	93,9	G545-24-20	104,9	-	-
1 1/2"	G543-24-24	91,7	G544-24-24	102,2	G545-24-24	126,5	G943-24-24	G945-24-24
1 1/2"	G543-32-24	70,9	G544-32-24	102,2	G545-32-24	133,5	-	-
2"	G543-32-32	106,2	G544-32-32	113,1	G545-32-32	156,0	G943-32-32	G945-32-32
2"	G543-24-32	-	G544-24-32	-	G545-24-32	-	-	-

- = Not available

SAE 6000 psi with O-Ring

Hose Dia.	Straight SAE flange		90° SAE flange		45° SAE flange		Split flange	Monoblock
	Part No	B	Part No	B	Part No	B	Part No	Part No
	1/2"	G546-08-08	55,5	G547-08-08	50,5	G548-08-08	56,5	G944-08-08
5/8"	G546-12-10	58,7	G547-12-10	59,7	G548-12-10	76,7	-	-
3/4"	G546-12-12	63,0	G547-12-12	61,0	G548-12-12	73,0	G944-12-12	G946-12-12
3/4"	G546-16-12	63,0	G547-16-12	81,0	G548-16-12	79,0	-	-
1"	G546-16-16	68,6	G547-16-16	78,6	G548-16-16	90,6	G944-16-16	G946-16-16
1"	G546-20-16	68,2	G547-20-16	76,8	G548-20-16	101,2	-	-
1 1/4"	G546-20-20	74,9	G547-20-20	93,9	G548-20-20	104,9	G944-20-20	G946-20-20
1 1/4"	G546-24-20	88,9	G547-24-20	93,9	G548-24-20	104,9	-	-
1 1/2"	G546-24-24	91,7	G547-24-24	102,2	G548-24-24	126,5	G944-24-24	G946-24-24
1 1/2"	G546-32-24	79,7	G547-32-24	102,2	G548-32-24	126,5	-	-
2"	G546-32-32	106,0	G547-32-32	133,1	G548-32-32	156,0	G944-32-32	G946-32-32
2"	G546-24-32	-	G547-24-32	-	G5486-24-32	-	-	-

- = Not available

HOSES

GS-Serie couplings

Catepillar Style O-Ring Flange

Conn.	Hose Dia.	Straight SAE flange		22° SAE flange		30° SAE flange		45° SAE flange	
		Part No	B	Part No	B	Part No	B	Part No	B
3/4"	3/4"	G583-12-12	94,0	G586-12-12	92,0	G587-12-12	89,0	G585-12-12	82,0
3/4"	3/4"	G583-12-12L	-	G586-12-12L	-	G587-12-12L	-	G585-12-12L	-
3/4"	3/4"	G583-12-12S	-	G586-12-12S	-	G587-12-12S	-	G585-12-12S	-
1"	3/4"	G583-16-12	94,0	G586-16-12	-	G587-16-12	90,0	G585-16-12	82,0
1"	3/4"	G583-16-12S	-	G586-16-12S	-	G587-16-12S	-	G585-16-12S	-
1"	1"	G583-16-16	98,2	G586-16-16	95,9	G587-16-16	93,7	G585-16-16	86,3
1"	1"	G583-16-16S	-	G586-16-16S	-	G587-16-16S	-	G585-16-16S	-
1"	1"	G583-16-16L	-	G586-16-16L	-	G587-16-16L	-	G585-16-16L	-
1 1/4"	1"	G583-20-16	98,2	G586-20-16	95,9	G587-20-16	93,7	G585-20-16	86,3
1 1/4"	1 1/4"	G583-20-20	115,9	G586-20-20	113,9	G587-20-20	111,0	G585-20-20	104,9
1 1/4"	1 1/4"	G583-20-20S	-	G586-20-20S	-	G587-20-20S	-	G585-20-20S	-
1 1/2"	1 1/4"	G583-24-20	115,9	G586-24-20	113,9	G587-24-20	111,9	G585-24-20	115,9
1 1/2"	1 1/4"	G583-24-20S	-	G586-24-20S	-	G587-24-20S	-	G585-24-20S	-
1 1/2"	1 1/2"	G583-24-24	91,7	G586-24-24	-	G587-24-24	-	G585-24-24	155,8
2"	1 1/2"	G583-32-24	117,7	G586-32-24	-	G587-32-24	-	G585-32-24	181,2
2"	2"	G583-32-32	106,0	G586-32-32	-	G587-32-32	-	G585-32-32	156,0

Catepillar Style O-Ring Flange

Conn.	Hose Dia.	60° SAE flange		67° SAE flange		90° SAE flange	
		Part No	B	Part No	B	Part No	B
3/4"	3/4"	G588-12-12	-	G589-12-12	-	G584-12-12	-
3/4"	3/4"	G588-12-12L	-	G589-12-12L	-	G584-12-12L	66,0
3/4"	3/4"	G588-12-12S	-	G589-12-12S	-	G584-12-12S	74,0
1"	3/4"	G588-16-12	95,0	G589-16-12	-	G584-16-12	-
1"	3/4"	G588-16-12S	-	G589-16-12S	-	G584-16-12S	66,0
1"	1"	G588-16-16	106,0	G589-16-16	99,0	G584-16-16	-
1"	1"	G588-16-16S	-	G589-16-16S	-	G584-16-16S	74,1
1"	1"	G588-16-16L	-	G589-16-16L	-	G584-16-16L	74,1
1 1/4"	1"	G588-20-16	106,0	G589-20-16	99,0	G584-20-16	74,1
1 1/4"	1 1/4"	G588-20-20	126,9	G589-20-20	119,9	G584-20-20	-
1 1/4"	1 1/4"	G588-20-20S	-	G589-20-20S	-	G584-20-20S	94,9
1 1/2"	1 1/4"	G588-24-20	126,9	G589-24-20	119,9	G584-24-20	-
1 1/2"	1 1/4"	G588-24-20S	-	G589-24-20S	-	G584-24-20S	94,9
1 1/2"	1 1/2"	G588-24-24	-	G589-24-24	-	G584-24-24	102,2
2"	1 1/2"	G588-32-24	106,0	G589-32-24	-	G584-32-24	-
2"	2"	G588-32-32	-	G589-32-32	-	G584-32-32	133,1

- = Not available

ORFS/SAE Flat Face O-Ring

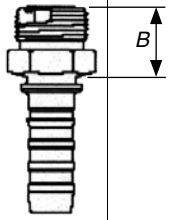
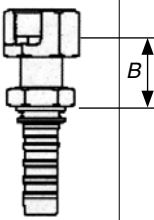
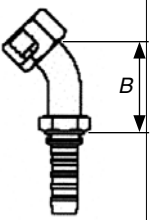
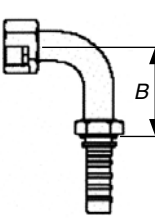
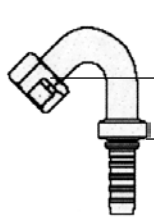
											
Conn.	Hose Dia.	Male straight		Female straight		Female 45°		Female 90°		Female 135°	
		Part No	B	Part No	B	Part No	B	Part No	B	Part No	B
11/16"-12UN	3/8"	G560-06-06S	-	G561-06-06S	-	G562-06-06S	-	G563-06-06S	42,2	G564-06-06S	-
11/16"-12UN	3/8"	G560-06-06L	-	G561-06-06L	-	G562-06-06L	-	G563-06-06L	49,2	G564-06-06L	-
11/16"-16UN	3/8"	G560-06-06	28,2	G561-06-06	33,2	G562-06-06	46,2	G563-06-06	-	G564-06-06	-
13/16"-12UN	3/8"	G560-08-06	-	G561-08-06	36,2	G562-08-06	57,2	G563-08-06	49,2	G564-08-06	-
13/16"-16UN	1/2"	G560-08-08	30,5	G561-08-08	35,5	G562-08-08	56,5	G563-08-08	-	G564-08-08	-
13/16"-12UN	1/2"	G560-08-08S	-	G561-08-08S	-	G562-08-08S	-	G563-08-08S	48,5	G564-08-08S	-
1"-14UNS	1/2"	G560-10-08	-	G561-10-08	40,5	G562-10-08	61,5	G563-10-08	63,5	G564-10-08	-
13/16"-12UN	1/2"	G560-12-08S	-	G561-12-08S	-	G562-12-08S	-	G563-12-08S	69,5	G564-12-08S	-
13/16"-12UN	1/2"	G560-12-08	-	G561-12-08	41,5	G562-12-08	-	G563-12-08	-	G564-12-08	-
1"-14UNS	5/8"	G560-10-10	-	G561-10-10	43,7	G562-10-10	60,7	G563-10-10	56,7	G564-10-10	-
1"-14UNS	5/8"	G560-10-10L	-	G561-10-10L	-	G562-10-10L	-	G563-10-10L	62,7	G564-10-10L	-
1"-14UNS	3/4"	G560-10-12	-	G561-10-12	46,0	G562-10-12	-	G563-10-12	-	G564-10-12	-
1"-14UNS	3/4"	G560-10-12S	-	G561-10-12S	-	G562-10-12S	-	G563-10-12S	60,0	G564-10-12S	-
13/16"-12UN	3/4"	G560-12-12S	-	G561-12-12S	-	G562-12-12S	-	G563-12-12S	77,0	G564-12-12S	-
13/16"-UN	3/4"	G560-12-12	-	G561-12-12	48,0	G562-12-12	74,0	G563-12-12	77,0	G564-12-12	-
13/16"-12UN	3/4"	G560-12-12L	-	G561-12-12L	-	G562-12-12L	-	G563-12-12L	77,0	G564-12-12L	-
17/16"-12UN	3/4"	G560-16-12S	-	G561-16-12S	-	G562-16-12S	-	G563-16-12S	86,0	G564-16-12S	-
17/16"-12UN	3/4"	G560-16-12	44,0	G561-16-12	52,0	G562-16-12	86,0	G563-16-12	-	G564-16-12	37,5
17/16"-12UN	1"	G560-16-16S	-	G561-16-16S	-	G562-16-16S	-	G563-16-16S	87,6	G564-16-16S	-
17/16"-12UN	1"	G560-16-16	45,2	G561-16-16	54,4	G562-16-16	87,8	G563-16-16	87,6	G564-16-16	-
17/16"-12UN	1"	G560-16-16L	-	G561-16-16L	-	G562-16-16L	-	G563-16-16L	87,6	G564-16-16L	-
1.11/16"-12UN	1"	G560-20-16S	-	G561-20-16S	-	G562-20-16S	-	G563-20-16S	97,6	G564-20-16S	-
1.11/16"-12UN	1"	G560-20-16	-	G561-20-16	54,3	G562-20-16	107,6	G563-20-16	97,6	G564-20-16	-
111/16"-12UN	1 1/4"	G560-20-20S	-	G561-20-20S	-	G562-20-20S	-	G563-20-20S	100,9	G564-20-20S	-
111/16"-12UN	1 1/4"	G560-20-20	48,9	G561-20-20	56,9	G562-20-20	108,8	G563-20-20	100,9	G564-20-20	-
111/16"-12UN	1 1/4"	G560-20-20L	-	G561-20-20L	-	G562-20-20L	-	G563-20-20L	100,9	G564-20-20L	-
2"-12UN	1 1/4"	G560-24-20	-	G561-24-20	58,9	G562-24-20	-	G563-24-20	-	G564-24-20	-
2"-12UN	1 1/2"	G560-24-24	-	G561-24-24	59,2	G562-24-24	138,7	G563-24-24	118,8	G564-24-24	-

- = Not available

Komatsu Style SAE Flange

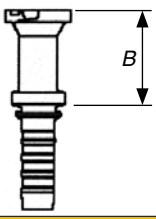
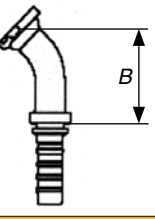
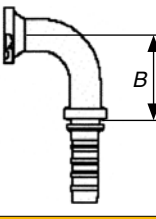
							
Conn.	Hose Dia.	Straight SAE flange		G555-45° SAE flange		G554-90° SAE flange	
		Part No	B	Part No	B	Part No	B
5/8"	1/2"	G553-10-08	44,1	G555-10-08	-	G554-10-08	-
5/8"	5/8"	G553-10-10	63,7	G555-10-10	70,7	G554-10-10	59,7
5/8"	3/4"	G553-10-12	59,0	G555-10-12	-	G554-10-12	67,0

- = Not available