

# ADAPTORS

Product	Page	Product	Page
Index	392	726 - JIC/BSP 60°	405
RA - Male/Male (BSP/BSP)	394	729 - Male/Female (NPT/NPT)	405
723 - Male/Male (BSP/BSPT)	395	730 - Male/Male (NPT/NPT)	406
724 - Male/Female (BSP/BSP)	395	719 - Fixed Female (NPT)	406
725 - Male/Female (BSP/BSP)	396	734 - 90° Fixed Female (NPT)	407
MF - Fixed Female (BSP)	396	735 - T, Fixed Female (NPT)	407
KM - Nut for Bulkhead	397	736 - 90° Male/Male (NPT)	408
727 - Bulkhead (BSP/BSP)	397	737 - 90° Male/Fixed Female (NPT)	408
703 - Blanking Cap (BSP)	398	738 - 45° Male/Fixed Female (NPT)	409
704 - Blanking Plug (BSP)	398	739 - 90° Male/Fixed Female (NPT)	409
707 - Swivel BSP Female	399	732 - Fixed Female (NPT)	410
708 - Swivel (BSP/BSP)	399	733 - Blanking Plug (NPT)	410
731 - Compact Swivel (BSP/BSP)	400	Bonded Seal (for BSP)	411
743 - Swivel 45° Male/Female (BSP/BSP)	400	750 - O.R.F.S Straight Union (UNF)	412
744 - Swivel 90° Male/Female (BSP/BSP)	401	751 - O.R.F.S Union 90° Elbow (UNF)	412
746 - Tee Swivel (BSP/BSP)	401	752 - O.R.F.S Male Connector (UNF/BSF)	413
747 - Tee/BSP Male/Swivel/Male	402	753 - O.R.F.S Union Tee (UNF)	413
748 - Tee/BSP Male/Male/Swivel	402	754 - O.R.F.S Bulkhead Union (UNF)	414
741 - 90° Male/Male (BSP/BSPT)	403	755 - O.R.F.S Male Connector (UNF)	414
745 - BSP Tee 60°	403	756 - O.R.F.S 90° Swivel Nut Elbow (UNF)	415
716 - 90° Bend Female	404	757 - O.R.F.S Swivel Nut Branch Tee (UNF)	415
722 - Male (BSP/NPT)	404	758 - O.R.F.S Swivel Nut Male Connector (BSPP/UNF)	416
		759 - O.R.F.S Fitting Body Cap (UNF)	416
		760 - O.R.F.S Tube Plug (UNF)	417
		761 - O.R.F.S Nut (UNF)	417
		762 - O.R.F.S Sleeve	418
		763 - O.R.F.S Male Connector (UNF/Metric)	418
		O-Ring - O.R.F.S O-ring	419



# ADAPTORS

# ADAPTORS

## Index

GS-FLANGE  
SYSTEM

TUBES & PIPES

CLAMPS

VALVES

BITE TYPE  
FITTINGS

SAE J514 JIC  
FLARE FITTINGS

HOSES &  
COUPLINGS

ADAPTORS

OTHER  
COMPONENTS

MACHINES

TECHNICAL  
INFORMATION

RA-



page 394

723-



page 395

724-

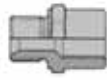

page 395

725-



page 396

MF-



page 396

KM-



page 397

727-



page 397

703-



page 398

704-



page 398

707-



page 399

708-



page 399

731-



page 400

743-



page 400

744-



page 401

746-

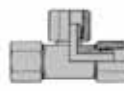

page 401

747-



page 402

748-



page 402

741-



page 403

745-



page 403

716-



page 404

722-



page 404

726-



page 405

729-



page 405

730-



page 406

719-

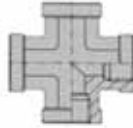

page 406

734-

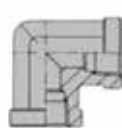

page 407

735-

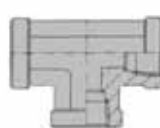

page 407

736-

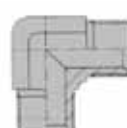

page 408

737-

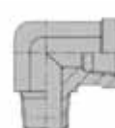

page 408

738-



page 409

739-



page 409

732-



page 410

733-



page 410

Bonded Seal



page 411

750-



page 412

751-



page 412

752-



page 413

753-



page 413

754-



page 414

755-



page 414

756-



page 415

757-



page 415

758-



page 416

759-



page 416

760-



page 417

761-



page 417

762-



page 418

763-



page 418

O-Ring



page 419

# ADAPTORS

RA-

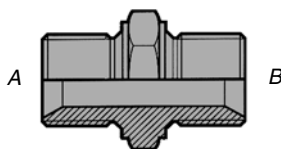

## Male/Male BSP/BSP

Part No	ID Code Steel	ID Code AISI 316	Thread conn.	
			A	B
RA-18-18	22030010	22040010	1/8	1/8
RA-14-18	22030015	22040015	1/4	1/8
RA- 14-14	22030020	22040020	1/4	1/4
RA- 38-18	22030025	22040025	3/8	1/8
RA- 38-14	22030030	22040030	3/8	1/4
RA- 38-38	22030035	22040035	3/8	3/8
RA- 12-18	22030040	22040040	1/2	1/8
RA- 12-14	22030045	22040045	1/2	1/4
RA- 12-38	22030050	22040050	1/2	3/8
RA- 12-12	22030055	22040055	1/2	1/2
RA- 58-58	22030060	22040060	5/8	5/8
RA- 58-12	22030065	22040065	5/8	1/2
RA- 34-38	22030070	22040070	3/4	3/8
RA- 34-12	22030075	22040075	3/4	1/2
RA- 34-34	22030080	22040080	3/4	3/4
RA-1-12	22030085	22040085	1	1/2
RA-1-34	22030090	22040090	1	3/4
RA-1-1	22030095	22040095	1	1
RA- 114-34	22030100	22040100	1 1/4	3/4
RA- 114-1	22030105	22040105	1 1/4	1
RA- 114-114	22030110	22040110	1 1/4	1 1/4
RA- 112-1	22030115	22040115	1 1/2	1
RA- 112-114	22030120	22040120	1 1/2	1 1/4
RA- 112-112	22030125	22040125	1 1/2	1 1/2
RA- 2-112	22030130	22040130	2	1 1/2
RA- 2-2	22030135	22040135	2	2

394

ADAPTORS

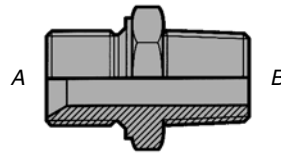

### Male/Male BSP/BSPT

Part No	ID Code Steel	ID Code AISI 316	Thread conn.	
			A	B
723-02-02	22030200	22040200	1/8	1/8
723-04-04	22030205	22040205	1/4	1/4
723-06-06	22030210	22040210	3/8	3/8
723-08-08	22030215	22040215	1/2	1/2
723-10-10	22030220	22040220	5/8	5/8
723-12-12	22030225	22040225	3/4	3/4
723-16-16	22030230	22040230	1	1
723-20-20	22030235	22040235	1 1/4	1 1/4
723-24-24	22030240	22040240	1 1/2	1 1/2
723-32-32	22030245	22040245	2	2

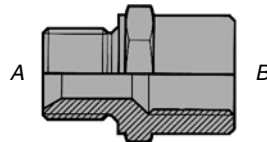

### Male/Female BSP/BSP

Part No	ID Code Steel	ID Code AISI 316	Thread conn.	
			A	B
724-02-02	22030300	22040300	1/8	1/8
724-04-04	22030305	22040305	1/4	1/4
724-06-06	22030310	22040310	3/8	3/8
724-08-08	22030315	22040315	1/2	1/2
724-10-10	22030320	22040320	5/8	5/8
724-12-12	22030325	22040325	3/4	3/4
724-16-16	22030330	22040330	1	1
724-20-20	22030335	22040335	1 1/4	1 1/4
724-24-24	22030340	22040340	1 1/2	1 1/2
724-32-32	22030345	22040345	2	2

# ADAPTORS

## 725-, MF-

### Male/Female BSP/BSP

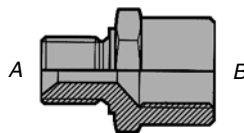

Part No	ID Code Steel	ID Code AISI 316	Thread conn.	
			A	B
725-02-04	22030400	22040400	1/8	1/4
725-04-02	22030405	22040405	1/4	1/8
725-04-06	22030410	22040410	1/4	3/8
725-04-08	22030415	22040415	1/4	1/2
725-06-04	22030420	22040420	3/8	1/4
725-06-08	22030425	22040425	3/8	1/2
725-08-06	22030430	22040430	1/2	3/8
725-08-10	22030435	22040435	1/2	5/8
725-08-12	22030440	22040440	1/2	3/4
725-10-08	22030445	22040445	5/8	1/2
725-10-12	22030450	22040450	5/8	3/4
725-12-08	22030455	22040455	3/4	1/2
725-12-16	22030460	22040460	3/4	1
725-16-12	22030465	22040465	1	3/4
725-16-20	22030470	22040470	1	1 1/4
725-20-16	22030475	22040475	1 1/4	1
725-20-24	22030480	22040480	1 1/4	1 1/2
725-24-20	22030485	22040485	1 1/2	1 1/4
725-24-32	22030490	22040490	1 1/2	2
725-32-24	22030495	22040495	2	1 1/2

### Fixed Female BSP

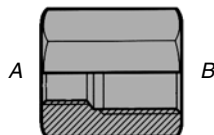

Part No	ID Code Steel	ID Code AISI 316	Thread conn.	
			A	B
MF-18-18	22030500	22040500	1/8	1/8
MF-14-18	22030505	22040505	1/4	1/8
MF-14-14	22030510	22040510	1/4	1/4
MF-38-14	22030515	22040515	3/8	1/4
MF-12-14	22030520	22040520	1/2	1/4
MF-38-38	22030525	22040525	3/8	3/8
MF-12-38	22030530	22040530	1/2	3/8
MF-34-38	22030535	22040535	3/4	3/8
MF-12-12	22030540	22040540	1/2	1/2
MF-34-12	22030545	22040545	3/4	1/2
MF-34-34	22030550	22040550	3/4	3/4
MF-1-34	22030555	22040555	1	3/4
MF-1-1	22030560	22040560	1	1
MF-114-1	22030565	22040565	1 1/4	1
MF-114-114	22030570	22040570	1 1/4	1 1/4
MF-112-114	22030575	22040575	1 1/2	1 1/4
MF-112-112	22030580	22040580	1 1/2	1 1/2
MF-2-2	22030585	22040585	2	2
MF-211-2	22030590	22040590	1 1/2	2

396



### Nut for Bulkhead

Part No	ID Code Steel	ID Code AISI 316	Thread conn.	
			A	B
KM-04	22030600	22040600	1/4	
KM-06	22030605	22040605	3/8	
KM-08	22030610	22040610	1/2	
KM-12	22030615	22040615	3/4	
KM-16	22030620	22040620	1	
KM-20	22030625	22040625	1 1/4	

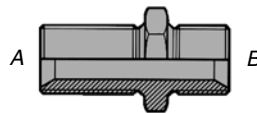

### Bulkhead BSP/BSP

Part No	ID Code Steel	ID Code AISI 316	Thread conn.	
			A	B
727-04-04	22030700	22040700	1/4	1/4
727-06-6	22030705	22040705	3/8	3/8
727-08-08	22030710	22040710	1/2	1/2
727-12-12	22030715	22040715	3/4	3/4
727-16-16	22030720	22040720	1	1
727-20-20	22030725	22040725	1 1/4	1 1/4

# ADAPTORS

## 703-, 704-

GS-FLANGE  
SYSTEM

TUBES & PIPES

CLAMPS

VALVES

BITE TYPE  
FITTINGS

SAE J514 JIC  
FLARE FITTINGS

HOSES &  
HOSE COUPLINGS

ADAPTORS

398

SPECIAL  
SOLUTIONS

MACHINES

TECHNICAL  
INFORMATION

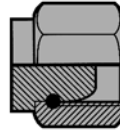

### Blanking Cap BSP

Part No	ID C55ode Steel	ID Code AISI 316	Thread conn.	
			A	B
703-02	22030800	22040800	1/8	
703-04	22030805	22040805	1/4	
703-06	22030810	22040810	3/8	
703-08	22030815	22040815	1/2	
703-10	22030820	22040820	5/8	
703-12	22030825	22040825	3/4	
703-16	22030830	22040830	1	
703-20	22030835	22040835	1 1/4	
703-24	22030840	22040840	1 1/2	
703-32	22030845	22040845	2	

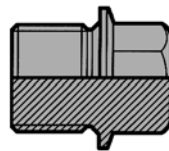

### Blanking Plug BSP

Part No	ID Code Steel	ID Code AISI 316	Thread conn.	
			A	B
704-02	22030900	22040900	1/8	
704-04	22030905	22040905	1/4	
704-06	22030910	22040910	3/8	
704-08	22030915	22040915	1/2	
704-10	22030920	22040920	5/8	
704-12	22030925	22040925	3/4	
704-16	22030930	22040930	1	
704-20	22030935	22040935	1 1/4	
704-24	22030940	22040940	1 1/2	
704-32	22030945	22040945	2	

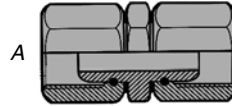

### Swivel BSP Female

Part No	ID Code Steel	ID Code AISI 316	Thread conn.	
			A	B
707-04-04	22031105	22041105	1/4	1/4
707-06-06	22031110	22041110	3/8	3/8
707-08-08	22031115	22041115	1/2	1/2
707-10-10	22031120	22041120	5/8	5/8
707-12-12	22031125	22041125	3/4	3/4
707-16-16	22031130	22041130	1	1
707-20-20	22031135	22041135	1 1/4	1 1/4

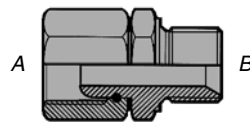

### Swivel BSP/BSP

Part No	ID Code Steel	ID Code AISI 316	Thread conn.	
			A	B
708-04-04	22031000	22041000	1/4	1/4
708-04-06	22031005	22041005	1/4	3/8
708-06-06	22031010	22041010	3/8	3/8
708-06-04	22031015	22041015	3/8	1/4
708-06-08	22031020	22041020	3/8	1/2
708-08-08	22031025	22041025	1/2	1/2
708-08-06	22031030	22041030	1/2	3/8
708-10-10	22031035	22041035	5/8	5/8
708-12-12	22031040	22041040	3/4	3/4
708-16-16	22031045	22041045	1	1
708-16-12	22031050	22041050	1	3/4
708-20-20	22031055	22041055	1 1/4	1 1/4
708-24-24	22031060	22041060	1 1/2	1 1/2



# ADAPTORS

## 731-, 743-

GS-FLANGE SYSTEM

TUBES & PIPES

CLAMPS

VALVES

BITE TYPE FITTINGS

SAE J514 JIC FLARE FITTINGS

HOSES & HOSE COUPLINGS

ADAPTORS

400

SPECIAL SOLUTIONS

MACHINES

TECHNICAL INFORMATION

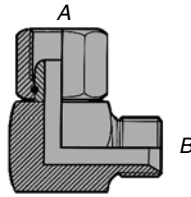

### Compact Swivel BSP/BSP

Part No	ID Code Steel	ID Code AISI 316	Thread conn.	
			A	B
731-04-04	22031200	22041200	1/4	1/4
731-06-06	22031205	22041205	3/8	3/8
731-08-08	22031210	22041210	1/2	1/2
731-10-10	22031215	22041215	5/8	5/8
731-12-12	22031220	22041220	3/4	3/4
731-16-16	22031225	22041225	1	1
731-20-20	22031230	22041230	1 1/4	1 1/4

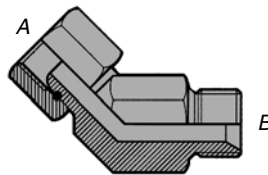

### Swivel 45° Male/Female BSP/BSP

Part No	ID Code Steel	ID Code AISI 316	Thread conn.	
			A	B
743-04-04	22031300	22041300	1/4	1/4
743-06-06	22031305	22041305	3/8	3/8
743-08-08	22031310	22041310	1/2	1/2
743-12-12	22031315	22041315	3/4	3/4
743-16-16	22031320	22041320	1	1
743-20-20	22031325	22041325	1 1/4	1 1/4

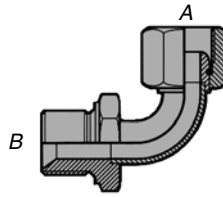

### Swivel 90° Male/Female BSP/BSP

Part No	ID Code Steel	ID Code AISI 316	Thread conn.	
			A	B
744-04-04	22031400	22041400	1/4	1/4
744-06-06	22031405	22041405	3/8	3/8
744-08-08	22031410	22041410	1/2	1/2
744-12-12	22031415	22041415	3/4	3/4
744-16-16	22031420	22041420	1	1
744-20-20	22031425	22041425	1 1/4	1 1/4

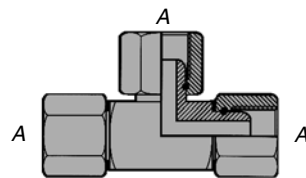

### Tee Swivel BSP/BSP

Part No	ID Code Steel	ID Code AISI 316	Thread conn.	
			A	B
746-04-04-04	22031500	22041500	1/2	
746-06-06-06	22031505	220415005	3/8	
746-08-08-08	22031510	22041510	1/2	
746-12-12-12	22031515	22041515	3/4	
746-16-16-16	22031520	22041520	1	

401

# ADAPTORS

747-, 748-

GS-FLANGE  
SYSTEM

TUBES & PIPES

CLAMPS

VALVES

BITE TYPE  
FITTINGS

SAE J514 JIC  
FLARE FITTINGS

HOSES &  
HOSE COUPLINGS

ADAPTORS

402

SPECIAL  
SOLUTIONS

MACHINES

TECHNICAL  
INFORMATION

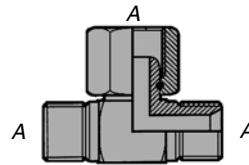

## Tee/BSP Male/Swivel/Male

Part No	ID C25ode Steel	ID Code AISI 316	Thread conn.	
			A	B
747-04-04	22031600	22041600	1/4	
747-06-06	22031605	22041605	3/8	
747-08-08	22031610	22041610	1/2	
747-12-12	22031615	22041615	3/4	
747-16-16	22031620	22041650	1	

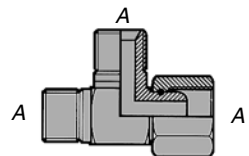

## Tee/BSP Male/Male/Swivel

Part No	ID Code Steel	ID Code AISI 316	Thread conn.	
			A	B
748-04-04	22031700	22041700	1/4	
748-06-06	22031705	22041705	3/8	
748-08-08	22031710	22041710	1/2	
748-12-12	22031715	22041715	3/4	
748-16-16	22031720	22041720	1	

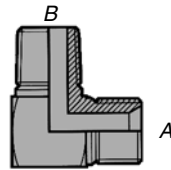

### 90° Male/Male BSP/BSPT

Part No	ID Code Steel	ID Code AISI 316	Thread conn.	
			A	B
741-04-04	22031800	22041800	1/4	1/4
741-06-06	22031805	22041805	3/8	3/8
741-08-08	22031810	22041810	1/2	1/2
741-12-12	22031815	22041815	3/4	3/4
741-16-16	22031820	22041820	1	1

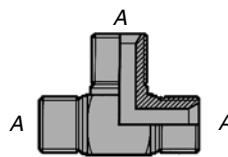

### BSP Tee 60°

Part No	ID Code Steel	ID Code AISI 316	Thread conn.	
			A	B
745-04	22031900	22041900	1/4	
745-06	22031905	22041905	3/8	
745-08	22031910	22041910	1/2	
745-12	22031915	22041915	3/4	
745-16	22031920	22041920	1	

# ADAPTORS

## 716-, 722-

GS-FLANGE  
SYSTEM

TUBES & PIPES

CLAMPS

VALVES

BITE TYPE  
FITTINGS

SAE J514 JIC  
FLARE FITTINGS

HOSES &  
HOSE COUPLINGS

ADAPTORS

SPECIAL  
SOLUTIONS

MACHINES

TECHNICAL  
INFORMATION

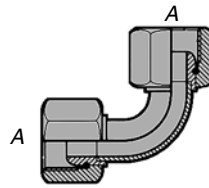

### 90° Bend Female

Part No	ID Code Steel	ID Code AISI 316	Thread conn.	
			A	B
716-04	22032000	22042000	1/4	
716-06	22032005	22042005	3/8	
716-08	22032010	22042010	1/2	
716-12	22032015	22042015	3/4	
716-16	22032020	22042020	1	

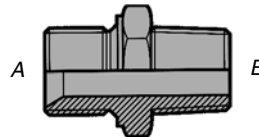

### Male BSP/NPT

Part No	ID Code Steel	ID Code AISI 316	Thread conn.	
			A	B
722-02-02	22032100	22042100	1/8	1/8
722-04-04	22032105	22042105	1/4	1/4
722-06-06	22032110	22042110	3/8	3/8
722-06-08	22032115	22042115	3/8	1/2
722-08-06	22032120	22042120	1/2	3/8
722-08-08	22032125	22042125	1/2	1/2
722-08-12	22032130	22042130	1/2	3/4
722-12-08	22032135	22042135	3/4	1/2
722-12-12	22032140	22042140	3/4	3/4
722-16-16	22032145	22042145	1	1
722-20-20	22032150	22042150	1 1/4	1 1/4
722-24-24	22032155	22042155	1 1/4	1 1/2

404

# ADAPTORS

## 726-, 729-

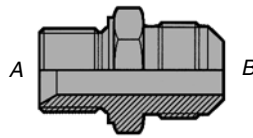

**JIC/BSP 60°**

Part No	ID Code Steel	ID Code AISI 316	Thread conn.	
			A	B
726-02-07	22032200	22042200	1/8	7/16-20
726-04-07	22032205	22042205	1/4	7/16-20
726-04-08	22032210	22042210	1/4	1/2-20
726-04-09	22032215	22042215	1/4	9/16-18
726-06-09	22032220	22042220	3/8	9/16-18
726-06-12	22032225	22042225	3/8	3/4-16
726-06-14	22032230	22042230	3/8	7/8-14
726-08-12	22032235	22042235	1/2	3/4-16
726-08-14	22032240	22042240	1/2	7/8-14
726-08-17	22032245	22042245	1/2	1 1/16-12
726-12-14	22032250	22042250	3/4	7/8-14
726-12-17	22032255	22042255	3/4	1 1/16-12
726-12-19	22032260	22042260	3/4	1 3/16-12
726-12-21	22032265	22042265	3/4	1 5/16-12
726-12-26	22032270	22042270	3/4	1 5/8-12
726-16-21	22032275	22042275	1	1 5/16-12
726-20-26	22032280	22042280	1 1/4	1 5/8-12
726-20-30	22032285	22042285	1 1/4	1 7/8-12
726-24-30	22032290	22042290	1 1/2	1 7/8-12
726-32-40	22032295	22042295	2	2 1/2-12

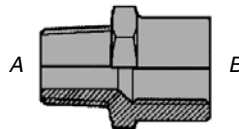

**Male/Female  
NPT/NPT**

Part No	ID Code Steel	ID Code AISI 316	Thread conn.	
			A	B
729-04-06	22032300	22042300	1/4	3/8
729-06-04	22032305	22042305	3/8	1/4
729-06-06	22032310	22042310	3/8	3/8
729-08-06	22032315	22042315	1/2	3/8
729-08-08	22032320	22042320	1/2	1/2
729-08-12	22032325	22042325	1/2	3/4
729-12-12	22032330	22042330	3/4	3/4
729-12-16	22032335	22042335	3/4	1
729-16-16	22032340	22042340	1	1
729-20-20	22032345	22042345	1 1/4	1 1/4
729-24-24	22032350	22042350	1 1/2	1 1/2
729-24-32	22032355	22042355	1 1/2	2
729-32-32	22032360	22042360	2	2

405

GS-FLANGE  
SYSTEM

TUBES & PIPES

CLAMPS

VALVES

BITE TYPE  
FITTINGS

SAE J514 JIC  
FLARE FITTINGS

HOSES &  
HOSE COUPLINGS

ADAPTORS

SPECIAL  
SOLUTIONS

MACHINES

TECHNICAL  
INFORMATION

# ADAPTORS

## 730-, 719-

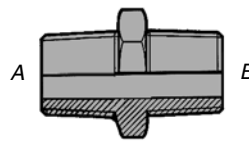

### Male/Male NPT/NPT

Part No	ID Code Steel	ID Code AISI 316	Thread conn.	
			A	B
730-02-02	22032400	2204200	1/8	1/8
730-04-02	22032405	2204205	1/4	1/8
730-04-04	22032410	2204210	1/4	1/4
730-04-06	22032415	2204215	1/4	3/8
730-06-02	22032420	2204220	3/8	1/8
730-06-06	22032425	2204225	3/8	3/8
730-06-08	22032430	2204230	3/8	1/2
730-08-08	22032435	2204235	1/2	1/2
730-08-12	22032440	2204240	1/2	3/4
730-12-12	22032445	2204245	3/4	3/4
730-12-16	22032450	2204250	3/4	1
730-12-20	22032455	2204255	3/4	1 1/4
730-16-16	22032460	2204260	1	1
730-20-16	22032465	2204265	1 1/4	1
730-20-20	22032470	2204270	1 1/4	1 1/4
730-24-24	22032475	2204275	1 1/4	1 1/2
730-24-32	22032480	2204280	1 1/2	2
730-32-32	22032485	2204285	2	2

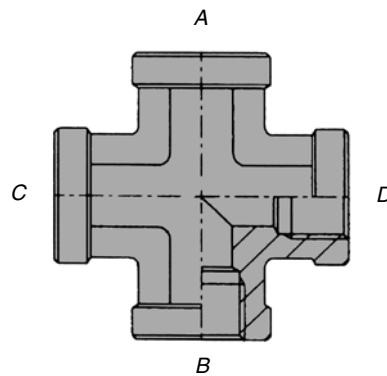

### Cross, All Fixed Female, Equal Size NPT

Part No	ID Code Steel	ID Code AISI 316	Thread conn.	
			A-B	C-D
719-04	22034300	22044300	1/4	1/4
719-06	22034305	22044305	3/8	3/8
719-08	22034310	22044310	1/2	1/2
719-12	22034315	22044315	3/4	3/4
719-16	22034320	22044320	1	1
719-20	22034325	22044325	1 1/4	1 1/4
719-24	22034330	22044330	1 1/2	1 1/2
719-32	22034335	22044335	2	2

406

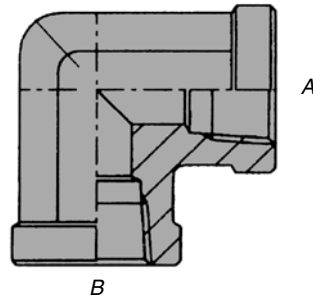

### 90° Fixed Female, Both Ends NPT

Part No	ID Code Steel	ID Code AISI 316	Thread conn.	
			A	B
734-04-04	22034340	22044340	1/4	1/4
734-06-06	22034345	22044345	3/8	3/8
734-08-08	22034350	22044350	1/2	1/2
734-12-12	22034355	22044355	3/4	3/4
734-16-16	22034360	22044360	1	1
734-20-20	22034365	22044365	1 1/4	1 1/4
734-24-24	22034370	22044370	1 1/2	1 1/2
734-32-32	22034375	22044375	2	2

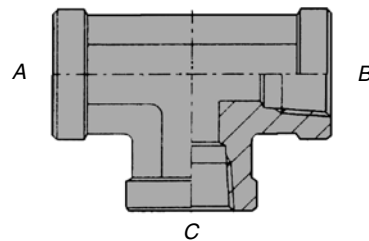

### T, Fixed Female, Equal Size NPT

Part No	ID Code Steel	ID Code AISI 316	Thread conn.	
			A-B	C
735-04-04	22034380	22044380	1/4	1/4
735-06-06	22034385	22044385	3/8	3/8
735-08-08	22034390	22044390	1/2	1/2
735-12-12	22034395	22044395	3/4	3/4
735-16-16	22034400	22044400	1	1
735-20-20	22034405	22044405	1 1/4	1 1/4
735-24-24	22034410	22044410	1 1/2	1 1/2
735-32-32	22034415	22044415	2	2



# ADAPTORS

## 736-, 737-

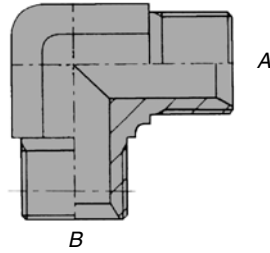

### 90° Male/Male NPT

Part No	ID Code Steel	ID Code AISI 316	Thread conn.	
			A	B
736-04-04	22034420	22044420	1/4	1/4
736-06-06	22034425	22044425	3/8	3/8
736-08-08	22034430	22044430	1/2	1/2
736-12-12	22034435	22044435	3/4	3/4
736-16-16	22034440	22044440	1	1
736-20-20	22034445	22044445	1 1/4	1 1/4
736-24-24	22034450	22044450	1 1/2	1 1/2
736-32-32	22034455	22044455	2	2

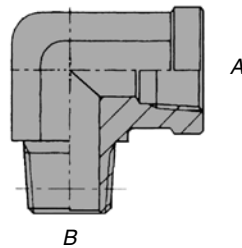

### 90° Male/Fixed Female NPT

Part No	ID Code Steel	ID Code AISI 316	Thread conn.	
			A	B
737-04-04	22034460	22044460	1/4	1/4
737-06-06	22034465	22044465	3/8	3/8
737-08-08	22034470	22044470	1/2	1/2
737-12-12	22034475	22044475	3/4	3/4
737-16-16	22034480	22044480	1	1
737-20-20	22034485	22044485	1 1/4	1 1/4
737-24-24	22034490	22044490	1 1/2	1 1/2
737-32-32	22034495	22044495	2	2

ADAPTORS

408

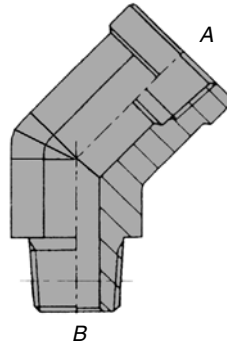

**45° Male/Fixed Female  
NPT**

Part No	ID Code Steel	ID Code AISI 316	Thread conn.	
			A	B
738-04-04	22034500	22044500	1/4	1/4
738-06-06	22034505	22044505	3/8	3/8
738-08-08	22034510	22044510	1/2	1/2
738-12-12	22034515	22044515	3/4	3/4
738-16-16	22034520	22044520	1	1
738-20-20	22034525	22044525	1 1/4	1 1/4
738-24-24	22034530	22044530	1 1/2	1 1/2
738-32-32	22034535	22044535	2	2

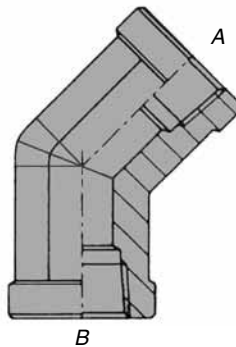

**45° Fixed Female, Both Ends  
NPT**

Part No	ID Code Steel	ID Code AISI 316	Thread conn.	
			A	B
739-04-04	22034540	22044540	1/4	1/4
739-06-06	22034545	22044545	3/8	3/8
739-08-08	22034550	22044550	1/2	1/2
739-12-12	22034555	22044555	3/4	3/4
739-16-16	22034560	22044560	1	1
739-20-20	22034565	22044565	1 1/4	1 1/4
739-24-24	22034570	22044570	1 1/2	1 1/2
739-32-32	22034575	22044575	2	2

# ADAPTORS

## 732-, 733-

GS-FLANGE SYSTEM

TUBES & PIPES

CLAMPS

VALVES

BITE TYPE FITTINGS

SAE J514 JIC FLARE FITTINGS

HOSES & HOSE COUPLINGS

ADAPTORS

SPECIAL SOLUTIONS

MACHINES

TECHNICAL INFORMATION

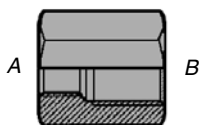

### Fixed Female NPT

Part No	ID Code Steel	ID Code AISI 316	Thread conn.	
			A	B
732-04-04	22032500	22042500	1/4	1/4
732-06-04	22032505	22042505	3/8	1/4
732-06-06	22032510	22042510	3/8	3/8
732-08-06	22032515	22042515	1/2	3/8
732-08-08	22032520	22042520	1/2	1/8
732-12-12	22032525	22042525	3/4	3/4
732-16-12	22032530	22042530	1	3/4
732-16-16	22032535	22042535	1	1
732-20-16	22032540	22042540	1 1/4	1
732-20-20	22032545	22042545	1 1/4	1 1/4
732-24-24	22032550	22042550	1 1/2	1 1/2
732-32-32	22032555	22042555	2	2

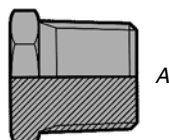

### Blanking Plug NPT

Part No	ID Code Steel	ID Code AISI 316	Thread Conn.
733-04	22032600	22042600	1/4
733-06	22032605	22042605	3/8
733-08	22032610	22042610	1/2
733-12	22032615	22042615	3/4
733-16	22032620	22042620	1
733-20	22032625	22042625	1 1/4
733-24	22032630	22042630	1 1/2
733-32	22032635	22042635	2

410

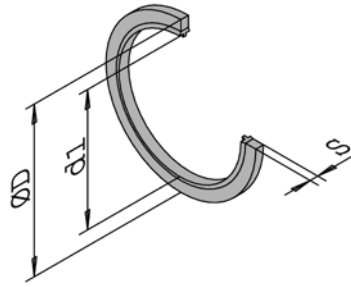

### Bonded Seal for BSP

Size	Part No	ID Code	S	D	D1
R1/4"	0821SC	19030510	2.10	20.63	13.71
R1/2"	1225SC	19030520	2.34	28.58	21.54
R3/4"	1629SC	19030530	2.34	34.93	27.05
R1"	2030SC	19030540	3.25	42.80	33.89
R1 1/4"	2432SC	19030550	3.25	52.38	42.93
R1 1/2"	2433SC	19030560	3.25	58.60	48.44
R2"	3236SC	19030570	3.25	73.03	60.58

# ADAPTORS

750-, 751-

O.R.F.S (O-Ring Face Seal Type Fittings)

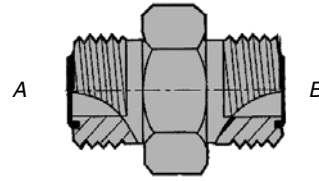

## Straight Union UNF Threads

Part No	ID Code	Thread A	Thread B
750-04-04	22032800	9/16"-18	9/16"-18
750-06-04	22032805	1 1/16"-16	9/16"-18
750-06-06	22032810	1 1/16"-16	1 1/16"-16
750-08-08	22032815	1 3/16"-16	1 3/16"-16
750-08-06	22032820	1 3/16"-16	1 1/16"-16
750-10-10	22032825	1"-14	1"-14
750-12-10	22032830	1 3/16"-12	1"-14
750-12-12	22032835	1 3/16"-12	1 3/16"-12
750-16-16	22032840	1 7/16"-12	1 7/16"-12
750-20-20	22032845	1 1/16"-12	1 1/16"-12
750-24-24	22032850	2"-12	2"-12

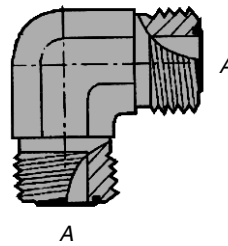

## Union 90° Elbow UNF Threads

Part No	ID Code	Thread A	Thread B
751-04-04	22032900	9/16"-18	
751-06-06	22032905	1 1/16"-16	
751-08-08	22032910	1 3/16"-16	
751-10-10	22032915	1"-14	
751-12-12	22032920	1 3/16"-12	
751-16-16	22032925	1 7/16"-12	
751-20-20	22032930	1 1/16"-12	
751-24-24	22032935	2"-12	

412

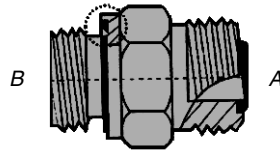

**Male Connector  
UNF/BSF Threads**

Part No	ID Code	Thread A	Thread B
752-04-02	22033000	9/16"-18	1/8"
752-04-04	22033005	9/16"-18	1/4"
752-04-06	22033010	9/16"-18	3/8"
752-04-08	22033015	9/16"-18	1/2"
752-06-04	22033020	1 1/16"-16	1/4"
752-06-06	22033025	1 1/16"-16	3/8"
752-06-08	22033030	1 1/16"-16	1/2"
752-08-04	22033035	1 3/16"-16	1/4"
752-08-06	22033040	1 3/16"-16	3/8"
752-08-08	22033045	1 3/16"-16	1/2"
752-08-12	22033050	1 3/16"-16	3/4"
752-10-06	22033055	1"-14	3/8"
752-10-08	22033060	1"-14	1/2"
752-10-12	22033065	1"-14	3/4"
752-10-16	22033070	1"-14	1"
752-12-08	22033075	1 3/16"-12	1/2"
752-12-12	22033080	1 3/16"-12	3/4"
752-12-16	22033085	1 7/16"-12	1"
752-12-20	22033090	1 1/16"-12	1 1/4"
752-16-12	22033095	1 7/16"-12	3/4"
752-16-16	22033100	1 7/16"-12	1"
752-16-20	22033105	1 11/16"-12	1 1/4"
752-20-16	22033110	1 11/16"-12	1"
752-20-20	22033115	1 11/16"-12	1 1/4"
752-20-24	22033120	1 7/16"-12	1 1/2"
752-24-24	22033125	2"-12	1 1/2"

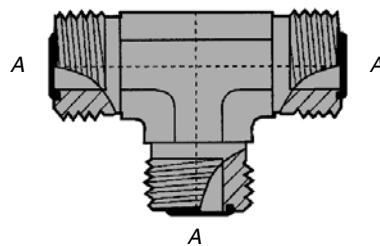

**Union Tee  
UNF Threads**

Part No	ID Code	Thread A	Thread B
753-04-04-04	22033200	9/16"-18	
753-06-06-06	22033205	1 1/16"-16	
753-08-08-08	22033210	1 3/16"-16	
753-10-10-10	22033215	1"-14	
753-12-12-12	22033220	1 3/16"-12	
753-16-16-16	22033225	1 7/16"-12	
753-20-20-20	22033230	1 1/16"-12	
753-24-24-24	22033235	2"-12	

# ADAPTORS

754-, 755-

O.R.F.S (O-Ring Face Seal Type Fittings)

GS-FLANGE SYSTEM  
TUBES & PIPES  
CLAMPS  
VALVES  
BITE TYPE FITTINGS  
SAE J514 JIC FLARE FITTINGS  
HOSES & HOSE COUPLINGS  
ADAPTORS  
SPECIAL SOLUTIONS  
MACHINES  
TECHNICAL INFORMATION

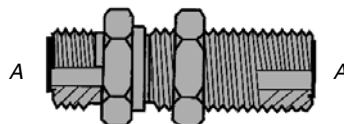

## Bulkhead Union UNF Threads

Part No	ID Code	Thread A	Thread B
754-04-04	22033300	9/16"-18	
754-06-06	22033305	1 1/16"-16	
754-08-08	22033310	1 3/16"-16	
754-10-10	22033315	1"-14	
754-12-12	22033320	1 3/16"-12	
754-16-16	22033325	1 7/16"-12	
754-20-20	22033330	1 1/16"-12	
754-24-24	22033335	2"-12	

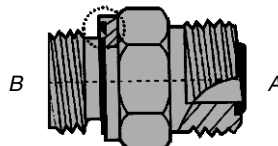

## Male Connector UNF Threads

Part No	ID Code	Thread A	Thread B
755-04-07	22033400	9/16"-18	7/16"-20
755-04-09	22033405	9/16"-18	9/16"-18
755-06-07	22033410	1 1/16"-16	7/16"-20
755-06-09	22033415	1 1/16"-16	9/16"-18
755-06-12	22033420	1 1/16"-16	3/4"-16
755-06-14	22033425	1 1/16"-16	7/8"-14
755-08-09	22033430	1 3/16"-16	9/16"-18
755-08-12	22033435	1 3/16"-16	3/4"-16
755-08-14	22033440	1 3/16"-16	7/8"-14
755-10-12	22033445	1"-14	3/4"-16
755-10-14	22033450	1"-14	7/8"-14
755-10-17	22033455	1"-14	1 1/16"-12
755-12-12	22033456	1 3/16"-12	3/4"-16
755-12-14	22033460	1 3/16"-12	7/8"-14
755-12-17	22033465	1 3/16"-12	1 1/16"-12
755-12-21	22033470	1 3/16"-12	1 5/16"-12
755-16-12	22033475	1 7/16"-12	1 5/16"-12
755-16-26	22033480	1 7/16"-12	1 5/8"-12
755-20-26	22033485	1 11/16"-12	1 5/8"-12
755-20-30	22033490	1 11/16"-20	1 7/8"-12
755-24-30	22033495	2"-12	1 7/8"-12

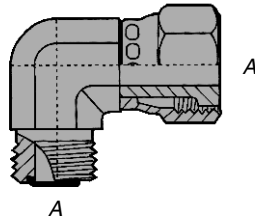

### 90° Swivel Nut Elbow UNF Threads

Part No	ID Code	Thread A	Thread B
756-04-04	22033500	9/16"-18	
756-06-06	22033505	1 1/16"-16	
756-08-08	22033510	1 3/16"-16	
756-10-10	22033515	1"-14	
756-12-12	22033520	1 3/16"-12	
756-16-16	22033525	1 7/16"-12	
756-20-20	22033530	1 11/16"-12	
756-24-24	22033535	2"-12	

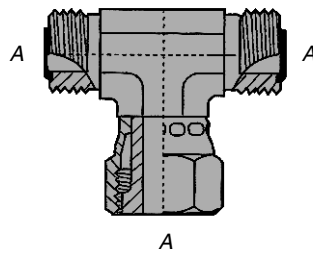

### Swivel Nut Branch Tee UNF Threads

Part No	ID Code	Thread A	Thread B
757-04-04-04	22033600	9/16"-18	
757-06-06-06	22033605	1 1/16"-16	
757-08-08-08	22033610	1 3/16"-16	
757-10-10-10	22033615	1"-14	
757-12-12-12	22033620	1 3/16"-12	
757-16-16-16	22033625	1 7/16"-12	
757-20-20-20	22033630	1 11/16"-12	
757-24-24-24	22033635	2"-12	



# ADAPTORS

758-, 759-

O.R.F.S (O-Ring Face Seal Type Fittings)

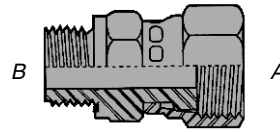

## Swivel Nut Male Connector BSPP/UNF

Part No	ID Code	Thread A	Thread B
758-04-20	22033700	9/16"-18	1/8"
758-04-04	22033705	9/16"-18	1/4"
758-06-04	22033710	1 1/16"-16	1/4"
758-06-06	22033715	1 1/16"-16	3/8"
758-08-06	22033720	1 3/16"-16	3/8"
758-08-08	22033725	1 3/16"-16	1/2"
758-10-08	22033730	1"-14	1/2"
758-12-12	22033735	1 3/16"-12	3/4"
758-16-16	22033740	1 7/16"-12	1"
758-20-20	22033745	1 11/16"-12	1 1/4"
758-24-24	22033750	2"-12	1 1/2"

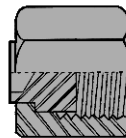

## Fitting Body Cap UNF Threads

Part No	ID Code	Thread A	Thread B
759-04	22033800	9/16"-18	
759-06	22033805	1 1/16"-16	
759-08	22033810	1 3/16"-16	
759-10	22033815	1"-14	
759-12	22033820	1 3/16"-12	
759-16	22033825	1 7/16"-12	
759-20	22033830	1 11/16"-12	
759-24	22033835	2"-12	

416

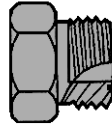

### Tube Plug UNF Threads

Part No	ID Code	Thread A	Thread B
760-04	22033900	9/16"-18	
760-06	22033905	1 1/16"-16	
760-08	22033910	1 3/16"-16	
760-10	22033915	1"-14	
760-12	22033920	1 3/16"-12	
760-16	22033925	1 7/16"-12	
760-20	22033930	1 11/16"-12	
760-24	22033935	2"-12	

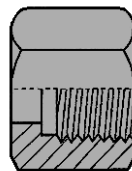

### Nut UNF Threads

Part No	ID Code	Thread A	Thread B
761-04	22034000	9/16"-18	
761-06	22034005	1 1/16"-16	
761-08	22034010	1 3/16"-16	
761-10	22034015	1"-14	
761-12	22034020	1 3/16"-12	
761-16	22034025	1 7/16"-12	
761-20	22034030	1 11/16"-12	
761-24	22034035	2"-12	

# ADAPTORS

## 762-, 763-

## O.R.F.S (O-Ring Face Seal Type Fittings)



### Sleeve

Part No	ID Code	Thread A	Pipe O.D.
762-06	22034100		6 mm
762-08	22034105		8 mm
762-10	22034110		10 mm
762-12	22034115		12 mm
762-14	22034120		14 mm
762-15	22034125		15 mm
762-16	22034130		16 mm
762-18	22034135		18 mm
762-20	22034140		20 mm
762-22	22034145		22 mm
762-25	22034150		25 mm
762-28	22034155		28 mm
762-30	22034160		30 mm
762-32	22034165		32 mm
762-35	22034170		35 mm
762-38	22034175		38 mm

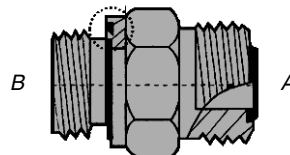

ADAPTORS

418

### Male Connector UNF/Metric

Part No	ID Code	Thread A	Thread B
763-04-04	22034200	9/16"-18	M12 x 1.5
763-06-06	22034205	1 1/16"-16	M14 x 1.5
763-08-08	22034210	1 3/16"-16	M18 x 1.5
763-10-10	22034215	1"-14	M22 x 1.5
763-12-12	22034220	1 3/16"-12	M27 x 2
763-16-16	22034225	1 7/16"-12	M33 x 2
763-20-20	22034230	1 11/16"-12	M42 x 2
763-24-24	22034235	2"-12	M48 x 2

GS-FLANGE  
SYSTEM

TUBES & PIPES

CLAMPS

VALVES

BITE TYPE  
FITTINGS

SAE J514 JIC  
FLARE FITTINGS

HOSES &  
HOSE COUPLINGS

SPECIAL  
SOLUTIONS

MACHINES

TECHNICAL  
INFORMATION



### ORFS O-Ring

Part No
764-04
764-06
764-08
764-10
764-12
764-16
764-20
764-24