



**Return-Suction Filters**

**E 158 · E 198 · E 248**

- Tank top mounting
- Connection up to G1<sup>1</sup>/<sub>4</sub>
- Nominal flow rate up to 250 l/min

## Description

### Application

For operation in units with hydrostatic drives, when the return flow is under all operating conditions higher than the oil flow of the boost pump.

### Performance features

Protection

against wear: By means of filter elements that, in full-flow filtration, meet even the highest demands regarding cleanliness classes.

Suction filter

function: Because of the 100%-filtration of the suction flow, no dirt can get into the boost pump.

Return filter

function: By means of full-flow filtration in the system return, the pumps above all are protected from dirt particles remaining in the system after assembly, repairs, or which are generated by wear or enter the system from outside.

### Functional characteristics

The hydraulic oil returning from the circuit (A) passes the filter element (1), is pressurized by a 0,5 bar check valve (2) and supplied to the boost pump (B). The surplus oil flows filtered over the integral check valve into the reservoir. As the boost pump is always fed with pressurized oil the risk of cavitation is minimized and full performance is available even during the critical cold start phase.

An integral pressure relief valve (3) prevents too high back pressure and protects the shaft seals against damages. As this valve leads the oil directly into the tank there is no direct connection between the return line (A) and the connection of the boost pump (B) (no bypass valve function).

Function (schematic):

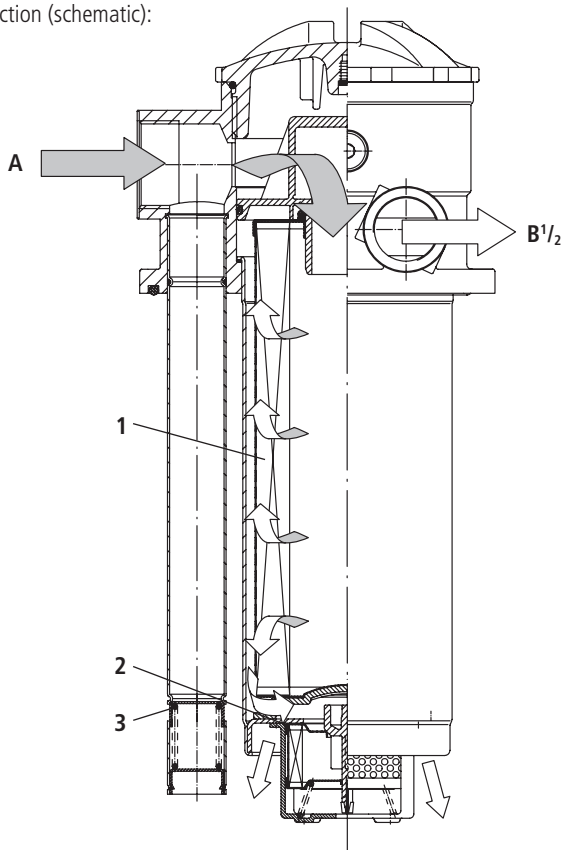

The emergency-suction valve (4) with 125 µm protection strainer (5) supplies the boost pump in case of a short term of lack of oil. During normal operation, a lack of oil may definitely not occur (refer to „Design“ section).

Emergency-suction (schematic):

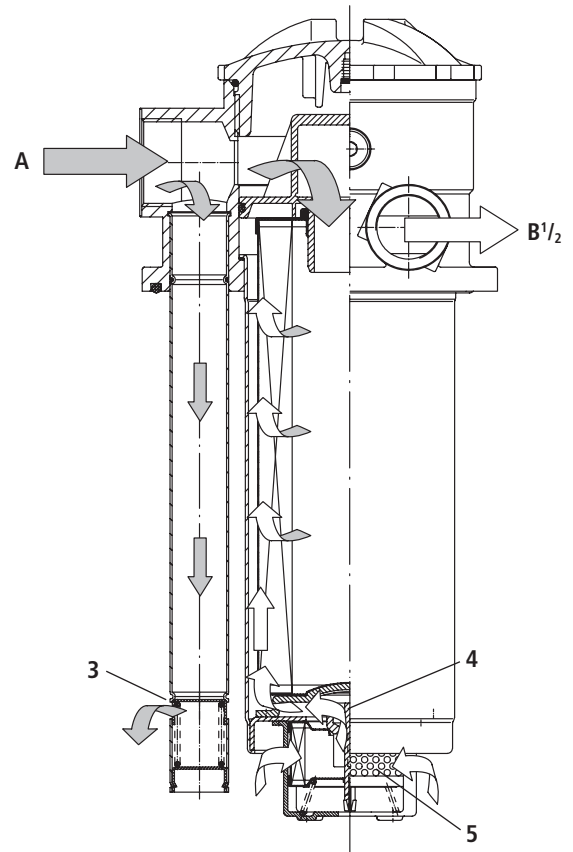

### Start up /Deaeration

For units with emergency-suction valve and protection strainer the start up set E 198.1710 can be used to de-aerate the hydraulic system at first start up or at start up after repair; hereby the immediate supply of the boost pump with hydraulic oil is guaranteed.

For all other types, deaerating instructions published by the manufacturers of hydraulic drives must be observed.

### Filter maintenance

By using a clogging indicator the correct moment for maintenance is indicated and guarantees therefore the optimum utilization of the filter elements.

### Filter elements

Flow direction from centre to the outside. The star-shaped pleating of the filter material results in:

- large filter surfaces
- low pressure drop
- high dirt-holding capacities
- long service life

Dirt deposits are entirely removed when the element is changed. Dirt cannot re-enter the tank.

### Accessories

Electrical and optical clogging indicators are available. Dimensions and technical data see catalogue sheet 60.20.

## Layout

### General

In machines with a hydrostatic drive and combined working hydraulic system, suction-return filters replace the suction or pressure filters previously required for the feed pump of the closed-loop hydrostatic drive circuit as well as the return filter for the open-loop working hydraulic circuit.

While each circuit operates independently with separate filters, the combination of the two circuits via the suction-return filter causes interaction between the circuits.

If the design criteria described below are taken into account, you can take full advantage of the benefits provided by the suction-return filter concept, thus making sure that your system performs reliably even under extreme operating conditions.

### Required return flow in the system

In order to maintain a precharging pressure of approx. 0,5 bar at the intake of the feed pump, the return flow must exceed the suction flow under any operating condition:

- Versions without hole ( $\varnothing$  4 mm) in the pressurizing valve: at least 10 l/min of excess flow
- Versions with hole ( $\varnothing$  4 mm) in the pressurizing valve: at least 20 l/min of excess flow

### Permitted feed pump flow rate

- at operating temperature ( $v < 60$  mm<sup>2</sup>/s, rpm=max):  
feed pump flow rate  $\leq 0,5$  x rated return flow according to column 2 of selection table
- at cold start-up ( $v < 1000$  mm<sup>2</sup>/s, rpm = 1000 min<sup>-1</sup>):  
feed pump flow rate  $\leq 0,2$  x rated return flow according to column of selection table

Please contact us if your system operates with higher flow rates than stated above.

### Flow velocity in the connecting lines

- Flow velocity in the return lines  $\leq 4,5$  m/s
- Flow velocity in the suction lines  $\leq 1,5$  m/s

### Permitted pressure in the suction lines

At cold start up ( $v < 1000$  mm<sup>2</sup>/s, rpm = 1000 min<sup>-1</sup>):  
feed pump flow rate  $\leq 0,2$  x rated return flow. The pressure loss in the suction lines must not exceed 0,4 bar.

### Backpressures in system return lines

If drain oil from the hydrostatic drive is routed across the filter in addition to the flow of the open-loop circuit, the following has to be observed in order to protect the shaft seals:

- permitted leakage oil pressure for a given viscosity and speed (manufacturer's specifications!)
- pressure loss caused by the leakage oil pipes
- pressure loss caused by the oil cooler used
- backpressure of the filter for a given flow rate or kinematic viscosity (refer to pressure loss diagrams)

Depending on the application, the use of a cooler bypass valve is recommended.

Generously sized drain oil pipes are also of advantage.

### Filter fineness grades

With the filter fineness grades available, the following oil cleanliness according to ISO 4406 can be achieved:

- 12 E-X: 18/15/12 ... 15/12/8
- 16 E-X: 20/17/12 ... 17/14/10

Even with the 16 E-X filter fineness grade, the requirements specified by manufacturers of hydrostatic drives are sometimes exceeded significantly. If components requiring a still better oil purity are used, we recommend the 12 E-X filter fineness grade.

### Suggested circuit layouts

A) The leakage oil of the hydrostatic drive is routed across the filter.

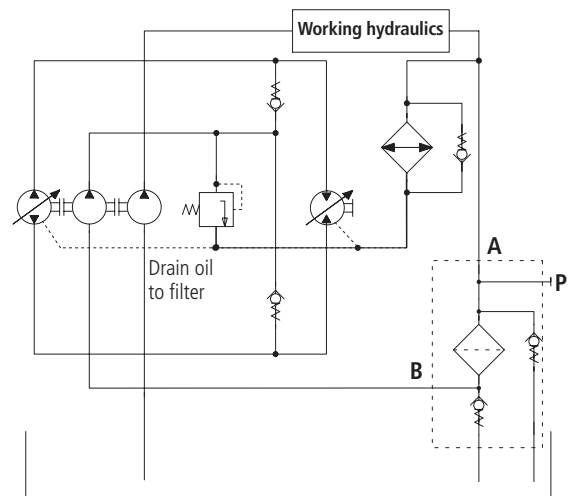

The entire dirt produced in the hydrostatic drive by abrasion is filtered out immediately and is thus not taken in by the pump of the open-loop circuit.

This circuit layout is always recommended if the return flow only slightly exceeds the suction flow, i.e. if there is a risk that the 0,5 bar precharging pressure cannot be maintained.

B) The drain oil of the hydrostatic drive is not routed across the filter but is discharged directly into the tank.

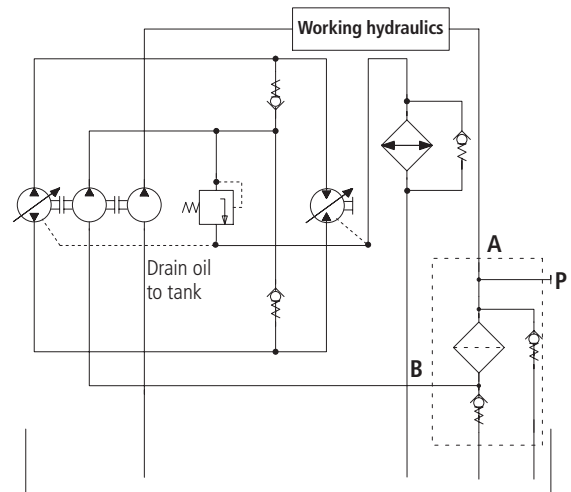

This circuit layout has the advantage that drain oil pressures are comparatively low.

# Characteristics

## Nominal flow rate

Up to 250 l/min in return line (see Selection Chart, column 2)

Up to 125 l/min Feed pump flow rate (see Layout)

The nominal flow rates indicated by ARGO-HYTOS are based on the following features:

- closed by-pass valve at  $v \leq 200 \text{ mm}^2/\text{s}$
- element service life > 1000 operating hours at an average fluid contamination of 0,07 g per l/min flow volume
- flow velocity in the return lines  $\leq 4,5 \text{ m/s}$
- flow velocity in the suction lines  $\leq 1,5 \text{ m/s}$

## Connection

Threaded ports according to ISO 228 or DIN 13. Sizes see Selection Chart, column 6 and 7

(other port threads on request)

## Filter fineness

12  $\mu\text{m(c)}$  ... 16  $\mu\text{m(c)}$

$\beta$ -values according to ISO 16889

(see Selection Chart, column 4 and Diagram Dx)

## Dirt-holding capacity

Values in g test dust ISO MTD according to ISO 16889

(see Selection Chart, column 5)

## Hydraulic fluids

Mineral oil and biodegradable fluids

(HEES and HETG, see info-service 00.20)

## Temperature range

- 30 °C ... + 100 °C (temporary - 40 °C ... + 120 °C)

## Viscosity at nominal flow rate

- at operating temperature:  $v < 60 \text{ mm}^2/\text{s}$
- as starting viscosity:  $v_{\text{max}} = 1000 \text{ mm}^2/\text{s}$
- at first operation: The recommended starting viscosity can be read from the Diagram D (pressure drop as a function of the kinematic viscosity) as follows: Find the 70%  $\Delta p$  of the cracking pressure of the by-pass valve on the vertical axis. Draw a horizontal line so that it intersects the  $\Delta p$  curve at a point. Read this point on the horizontal axis for the viscosity.

## Operating pressure

Max. 10 bar

## Materials

Screw-on cap: Polyester, GF reinforced

Filter head: Aluminium alloy

Filter bowl: Steel (E248), aluminium (E158, E198)

Seals: NBR (Viton on request)

Filter media: EXAPOR®MAX - inorganic multi-layer microfibre web

## Fitting position

- Standard type no restriction, preferably vertical
- Models with emergency-suction valve can vary up to 15° from the vertical
- Models with hole  $\varnothing 4 \text{ mm}$  in the check valve can vary up to 45° from the vertical

Even under unfavourable operating conditions (min. oil level, max. sloping) the oil outlet resp. emergency suction has to be below the oil level.

# Diagrams

## $\Delta p$ -curves for complete filters in Selection Chart, column 3

**D1** Pressure drop as a function of the **flow volume** at  $v = 35 \text{ mm}^2/\text{s}$  (0 = casing empty with hole  $\varnothing 4 \text{ mm}$ )

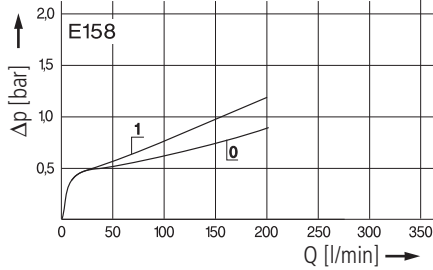

Pressure drop as a function of the **kinematic viscosity** at nominal flow

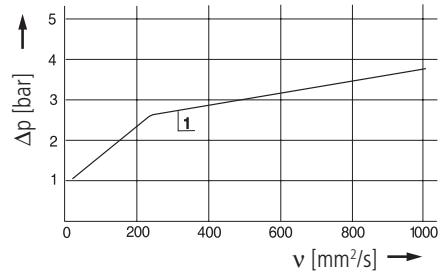

**D2** Pressure drop as a function of the **flow volume** at  $v = 35 \text{ mm}^2/\text{s}$  (00/01 = casing empty without/with hole  $\varnothing 4 \text{ mm}$ )

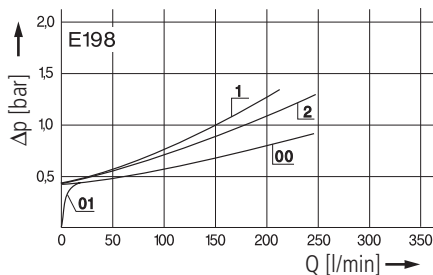

Pressure drop as a function of the **kinematic viscosity** at nominal flow

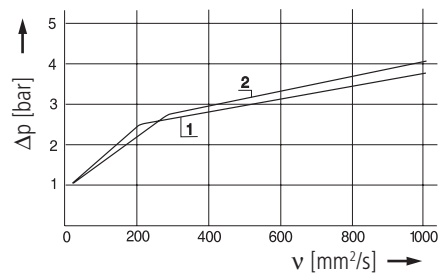

**D3** Pressure drop as a function of the **flow volume** at  $v = 35 \text{ mm}^2/\text{s}$  (0 = casing empty with hole  $\varnothing 4 \text{ mm}$ )

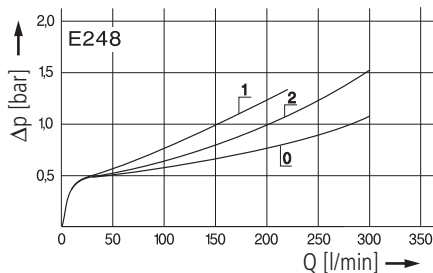

Pressure drop as a function of the **kinematic viscosity** at nominal flow

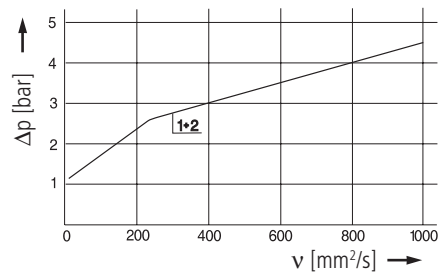

## Filter fineness curves in Selection Chart, column 4

**Dx** Filtration ratio  $\beta$  as a function of particle size  $x$  obtained by the Multi-Pass-Test according to ISO 16889

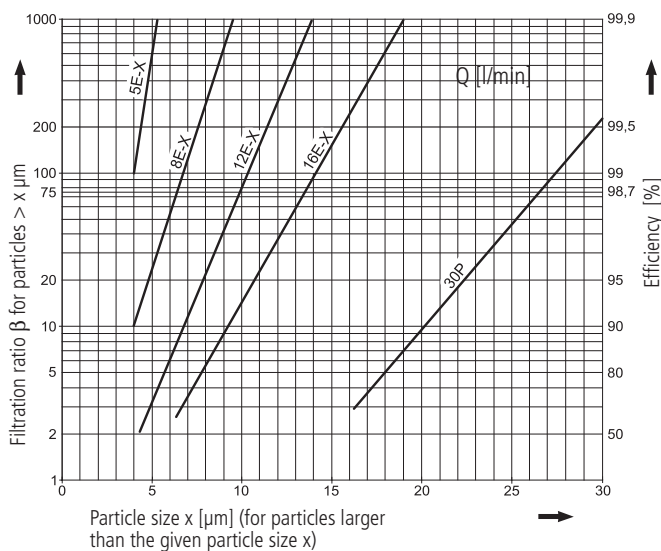

The abbreviations represent the following  $\beta$ -values resp. finenesses:

**For EXAPOR<sup>®</sup>MAX- and Paper elements:**

- 5 E-X** =  $\beta_{5(c)} = 200$  EXAPOR<sup>®</sup>MAX
- 8 E-X** =  $\beta_{8(c)} = 200$  EXAPOR<sup>®</sup>MAX
- 12 E-X** =  $\beta_{12(c)} = 200$  EXAPOR<sup>®</sup>MAX
- 16 E-X** =  $\beta_{16(c)} = 200$  EXAPOR<sup>®</sup>MAX
- 30 P** =  $\beta_{30(c)} = 200$  Paper

Based on the structure of the filter media of the 30 P paper elements, deviations from the printed curves are quite probable.

For special applications, finenesses differing from these curves are also available by using special composed filter material.

## Selection Chart

Part No.	Nominal return flow	Pressure drop see Diagram <b>D</b>	Filter fineness see Diagr. <b>DX</b>	Dirt-holding capacity	Connection A	Connections B <sub>1</sub> /B <sub>2</sub>	Cracking pressure of CV <sup>1</sup>	Cracking pressure of PRV <sup>2</sup>	Symbol	Replacement filter element Part No.	Weight	Remarks
1	l/min	3	4	g	6	7	bar	bar	10	11	kg	13
E 158-168	150	<b>D1/1</b>	16 E-X	45	G1¼	G1	0,5	2,5	4	V3.0923-08	3,0	3 + 4
E 198-156	150	<b>D2/1</b>	12 E-X	58	G1¼	G1	0,5	2,5	1	V3.0933-06	3,7	-
E 198-158	200	<b>D2/2</b>	16 E-X	64	G1¼	G1	0,5	2,5	1	V3.0933-08	3,7	-
E 198-168	200	<b>D2/2</b>	16 E-X	64	G1¼	G1	0,5	2,5	2	V3.0933-08	3,7	3
E 198-188	200	<b>D2/2</b>	16 E-X	64	G1¼	G1	0,5	2,5	4	V3.0933-08	3,8	3 + 4
E 248-156	190	<b>D3/1</b>	12 E-X	70	G1¼	G1	0,5	2,5	4	V3.0940-06	4,3	3 + 4
E 248-158	250	<b>D3/2</b>	16 E-X	77	G1¼	G1	0,5	2,5	4	V3.0940-08	4,3	3 + 4
E 248-258	250	<b>D3/2</b>	16 E-X	77	G1¼	G1	0,5	2,5	1	V3.0940-08	4,2	-

All filters are delivered with three plugged clogging indicator connections M 12 x 1,5. As clogging indicators on the return side (P<sub>1</sub>) either manometers or electrical pressure switches can be used. The monitoring of the vacuum on the suction side (P<sub>2</sub>) is additionally possible.

**For the appropriate clogging indicators see catalogue sheet 60.20.**

**Remarks:**

- The start of the red area respectively the switching pressure of the electrical pressure switch has always to be lower than the cracking pressure of the pressure relief valve (see Selection Chart, column 9).
- The clogging indicators are optional and always delivered detached from the filter.
- The filters listed in this chart are standard filters. If modifications are required, e.g. with integrated suction valve (integrated into the pressure relief valve) to guarantee the emergency steering feature for vehicles with official road use, we kindly ask for your request.
- For deaeration a start-up set for units with emergency-suction valve and protection strainer is available with Part No. E084.1710, for technical details see catalogue sheet 20.870.

<sup>1</sup> Cracking pressure of check valve

<sup>2</sup> Cracking pressure of pressure relief valve

<sup>3</sup> With hole Ø 4 mm in the check valve for oil drain when opening the filter cover

<sup>4</sup> With emergency-suction valve and protection strainer (125 µm)

## Dimensions

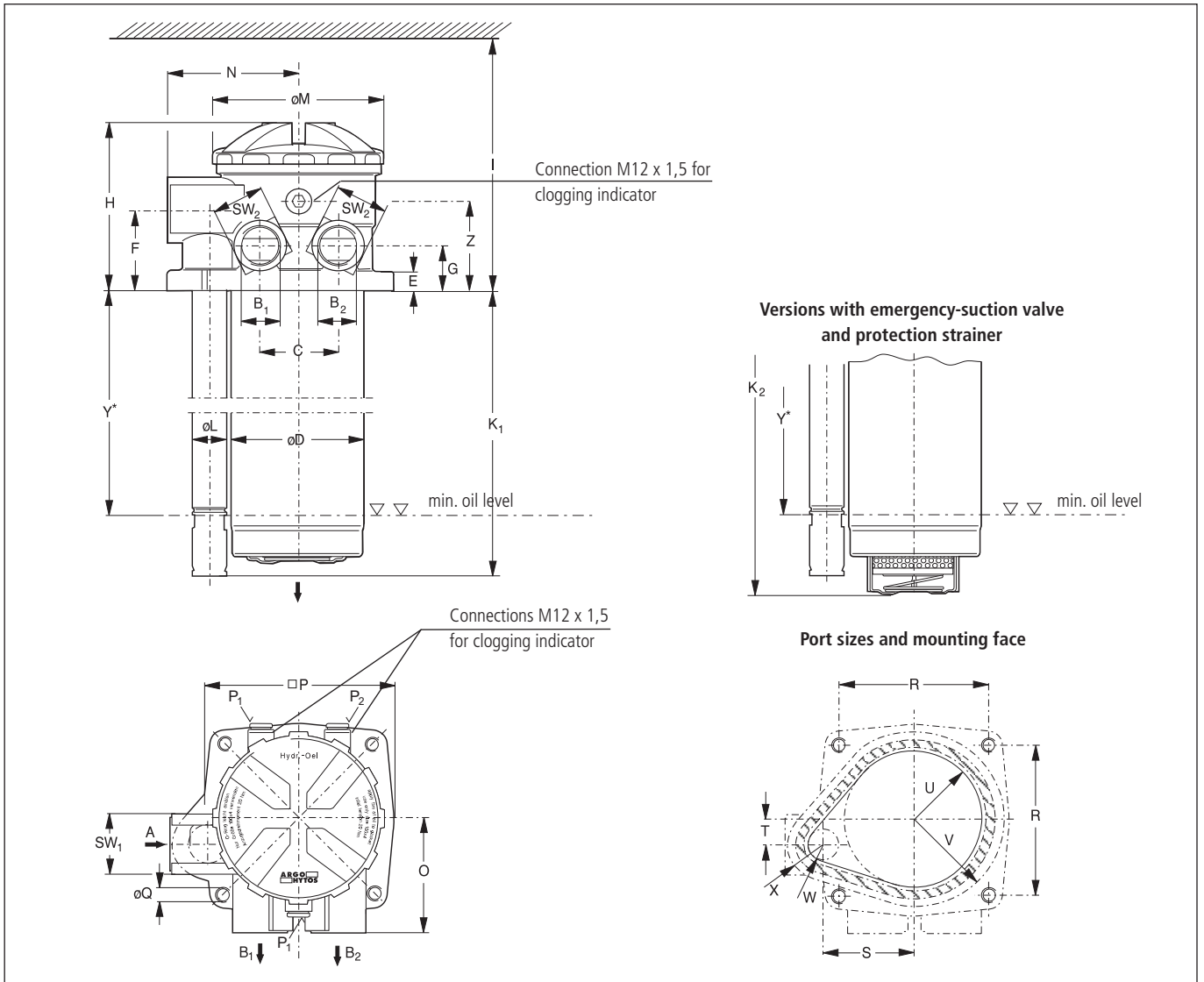

## Measurements

Type	A	B <sub>1/2</sub>	C	D	E	F	G	H	I	K <sub>1</sub>	K <sub>2</sub>	L	M	N	O	P	Q	R	S
E 158	G1¼	G1	56	100	11,5	61,5	30,5	130	430	244	254	28,5	126,5	97	85,5	141	11	116,5	68
E 198	G1¼	G1	56	100	11,5	61,5	30,5	130	530	340	355	28,5	126,5	97	85,5	141	11	116,5	68
E 248	G1¼	G1	56	100	11,5	61,5	30,5	130	600	410	420	28,5	126,5	97	85,5	141	11	116,5	68
Type	T	U	V	W	X	Y*	Z	SW <sub>1</sub>	SW <sub>2</sub>										
E 158	19,5	51	64	14,5	27	197	68	55	41										
E 198	19,5	51	64	14,5	27	298	68	55	41										
E 248	19,5	51	64	14,5	27	363	68	55	41										

\* Oil outlet resp. emergency suction has to be under all operating cond. below min. oil level (given by Y)

## Symbols

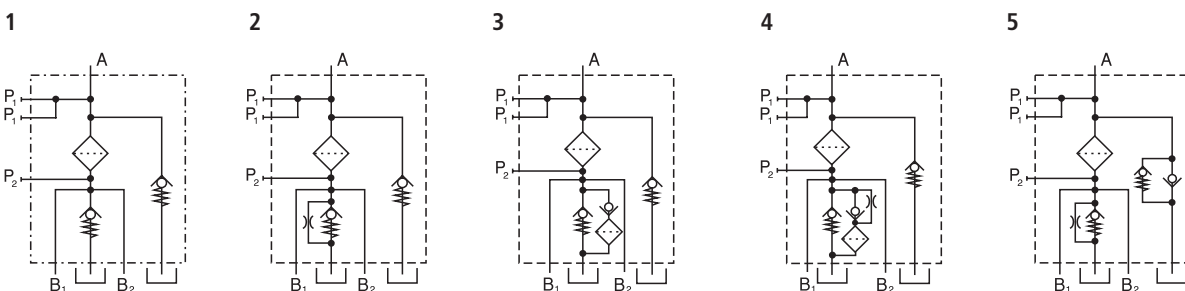

## Spare Parts

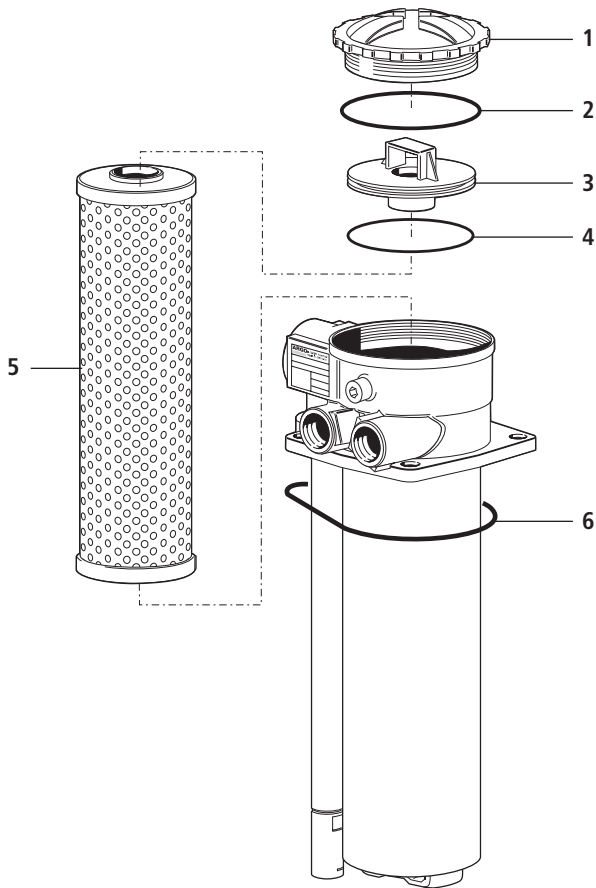

Pos.	Designation	Part No.
1	Screw-on cap	ES 074.0206
2	O-ring 100 x 4	N 007.1004
3	Inlet neck	E 198.0104
4	O-ring 98 x 3	N 007.0983
5	Filter element	see Chart / col. 11
6	O-ring 124 x 4,5	N 007.1245

The functions of the complete filters as well as the outstanding features of the filter elements assured by ARGO-HYTOS can only be guaranteed if original ARGO-HYTOS spare parts are used.

## Quality Assurance

### Quality management according to DIN EN ISO 9001

To ensure constant quality in production and operation, ARGO-HYTOS filter elements undergo strict controls and tests according to the following DIN and ISO standards:

<b>DIN ISO 2941</b>	Verification of collapse/burst resistance
<b>DIN ISO 2943</b>	Verification of material compatibility with fluids
<b>DIN ISO 3724</b>	Verification of flow fatigue characteristics

### ISO 2942 ISO 3968 ISO 16889

Verification of fabrication integrity (Bubble Point Test)  
Evaluation of pressure drop versus flow characteristics  
Multi-Pass-Test (evaluation of filter fineness and dirt-holding capacity)

Various quality controls during the production process guarantee the leakfree function and solidity of our filters.

Our engineers will be glad to advice you in questions concerning filter application, selection as well as the cleanliness class of the filtered medium attainable under practical operating conditions.

Illustrations may sometimes differ from the original. ARGO-HYTOS is not responsible for any unintentional mistake in this specification sheet.



### We produce fluid power solutions

ARGO-HYTOS GMBH · Industriestraße 9 · D-76703 Kraichtal

Tel: +49 7250 76-0 · Fax: +49 7250 76-199 · info.de@argo-hytos.com · www.argo-hytos.com